

A. WYCKOFF AND M. HANDSCHIEGL.
 ART OF COLORING CINEMATOGRAPHIC FILMS.
 APPLICATION FILED NOV. 20, 1916.

1,303,836.

Patented May 13, 1919.

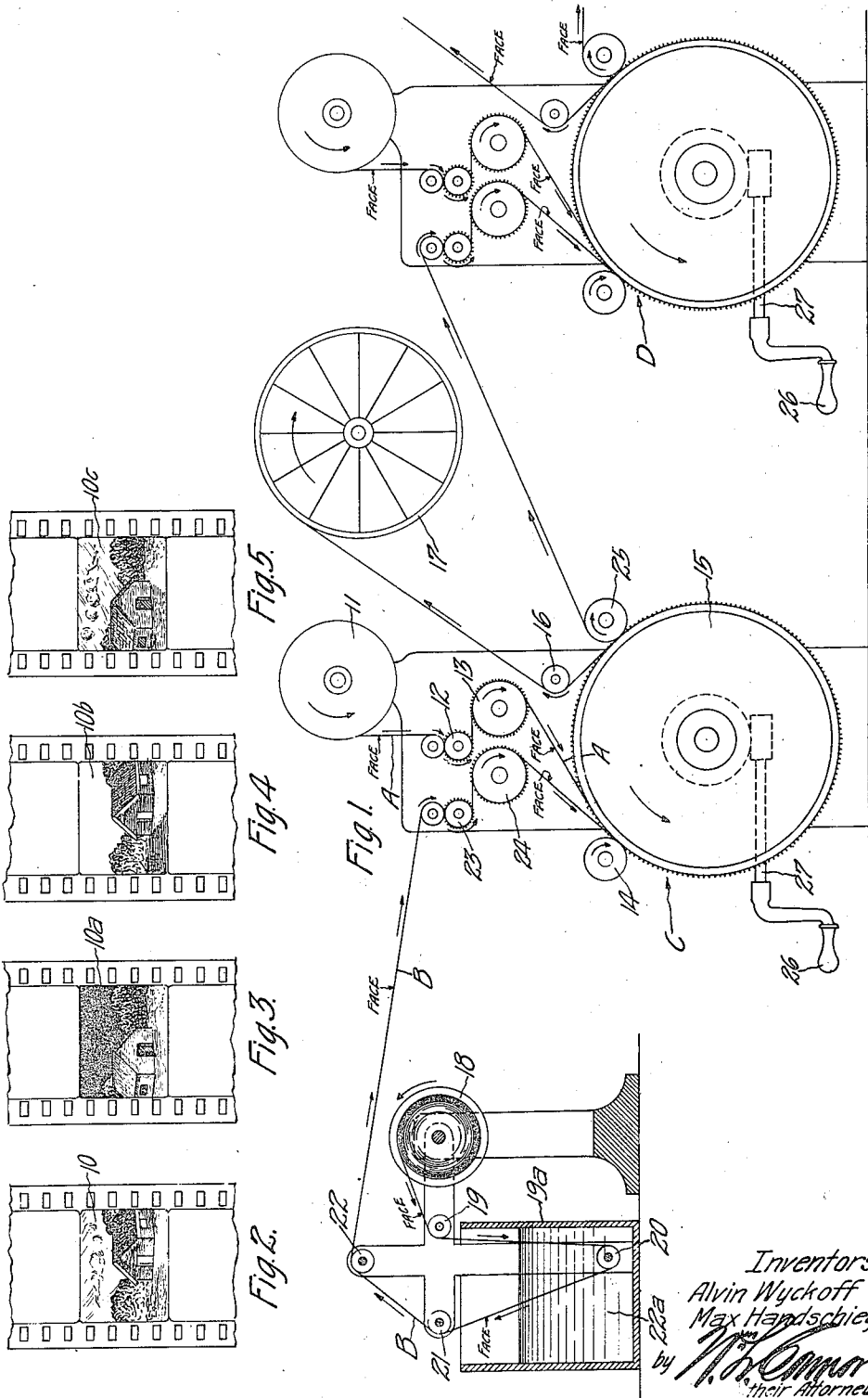

Inventors:
 Alvin Wyckoff and
 Max Handschiegl.
 by *W. C. Connor*
 their Attorney.

UNITED STATES PATENT OFFICE.

ALVIN WYCKOFF AND MAX HANDSCHIEGL, OF LOS ANGELES, CALIFORNIA, ASSIGNORS
TO FAMOUS PLAYERS-LASKY CORPORATION, A CORPORATION OF NEW YORK.

ART OF COLORING CINEMATOGRAPHIC FILMS.

1,303,836.

Specification of Letters Patent. Patented May 13, 1919.

Application filed November 20, 1916. Serial No. 132,350.

To all whom it may concern:

Be it known that we, ALVIN WYCKOFF and MAX HANDSCHIEGL, citizens of the United States, residing at Los Angeles, in the county of Los Angeles and State of California, have invented a new and useful Improvement in the Art of Coloring Cinematographic Films; and we do hereby declare the following to be a full, clear, and exact description of the invention, such as will enable others skilled in the art to which it appertains to make and use the same.

This invention relates to the art of coloring or tinting cinematographic films and the like, and particularly to films which have been exposed, developed and made ready for exhibition; and constitutes the process of applying soluble coloring matter, such as anilin dyes or like substances, to positive films by subjecting them to a pressurable contact with similar films carrying such coloring matter.

Heretofore the coloring or tinting of such films has been accomplished in various ways, chief among which are the stencil and direct methods. In the first named method a stencil is cut from a negative or fac-simile of the positive film to be colored, that portion of each view being cut out which corresponds to a similar portion on the positive it is desired to color. This stencil is then laid down upon the positive film and the coloring matter applied over its surface by hand or other means, thus coloring those portions of the positive film exposed through the apertures in the stencil. With this method a separate stencil must be cut for each separate color it is desired to apply to the positive film. In the direct method the coloring matter is applied directly to the finished positive film by means of a brush. Both of these methods are slow and expensive. As two films seldom shrink the same after being wet in the developing process, it is practically impossible with the stencil process to color more than a limited number of views at a time without readjustment of the stencil perforations to register with their corresponding portions on the positive film. Furthermore, the above named methods, in addition to being tedious and expensive, have been productive of unsatisfactory results, in that the coloring matter is generally unevenly ap-

plied, the outlines being blurred and indistinct, and the colors frequently overlapping other images in the picture.

In view of the foregoing this invention has for its prime object the rendering of the process of coloring such films more expeditious, less expensive and productive of perfect results.

In its broadest aspect, our process embraces the application of coloring matter to selected portions of a film, preferably a negative, and the subsequent transfer of such coloring matter to similarly selected portions of a positive print by bringing the two together in contact upon the periphery of a revoluble drum; while at the same time the films are drawn separately over stretching means, and brought into perfect register before coming in contact. In this manner two very objectionable features heretofore encountered in the art are entirely obviated, *i. e.*, first, by bringing the films to register before coming in contact upon the drum, the shifting of one film upon the other, which results in smearing the color, is avoided; and, second by exerting a constant and even longitudinal tension upon the films to bring them to register, such pressure is maintained by rolling them in even contact, thereby reducing to a minimum the possibility of their slipping out of register.

The merits of the invention will be more fully set forth in the following specification, reference being had to the accompanying drawings in which is illustrated an apparatus suitable for carrying out the various steps in the process, and in which:

Figure 1 is a diagrammatic view showing the apparatus used and the travel of the films therethrough in making the transfer of coloring matter:

Figs. 2, 3, 4 and 5 are views illustrating fragmentary sections of cinematographic films looking toward their sensitized surfaces.

The term "negative film" as will be hereinafter used shall be deemed to refer to any original film, carrying the original or first impressions made by exposure in the camera, or any fac-simile of said film reproduced therefrom by any means, or which carries views or portions of views identical with those of the original; and the term "posi-

tive film" shall be considered as referring to any film adapted to be used for final exhibition and which is an inverse fac-simile of the said original or negative, reproduced by any means. The term "face" refers to the gelatinous or sensitized surfaces of the films.

Referring now to the drawings let Fig. 2 represent the sensitized surface of a fragmentary section of negative film containing a series of views which comprises a scene in the picture. Say, for instance, it is desired to color the sky portion 10 blue in these views. A positive, as at Fig. 3, is taken from the said negative, and the sky portions 10^a to be colored are "stopped out" or covered over with a coating of material which is impervious to light; this may be done by hand with the aid of a brush or other suitable implement. The balance of the views are left in their normal state of development. A negative, as at Fig. 4, is then printed back from this coated positive on which the sky portions 10^b, which have been unexposed to light by reason of the coated portions 10^a of the positive, are undeveloped, the sensitized materials having been removed in the developing bath leaving only the gelatinous matter thereon, which is transparent. It is well known in photography that the gelatinous coating on a film becomes more insoluble or harder on those portions acted upon by light than on those parts where no exposure takes place. This negative is then immersed in a chemical solution such as bichromate or the like which fixes and solidifies the exposed or developed portions of the views, rendering such portions impervious to liquid, but does not affect the viscous consistency of the unexposed or transparent portions 10^b. After the fixing bath this negative is first allowed to dry after which it is immersed in a dye or any suitable soluble coloring matter, and allowed to remain until a quantity of coloring matter has thoroughly penetrated and adhered to the viscous surface of the transparent gelatinous portions 10^b. It is then allowed to dry after which it is ready for the transferring process by pressurable contact with the positive film, as at Fig. 5, for the coloring of the portion 10^c.

The above described process of applying the coloring matter to the negative film is the most preferable and inexpensive, however, equally good results may be obtained when the coloring matter is applied directly to the said negative by hand.

In this process a negative film is used as a support for the coloring matter for two reasons; first, because it discloses thereon a replica of that portion or image on the positive film it is desired to color and can be readily treated as above described, and, second, because a negative and positive film

may be placed together with their gelatinous surfaces in contact and with the views on each in perfect register with the other.

Referring now more particularly to Fig. 1, of the drawings, let A designate a negative film, which has been treated as above described, and B a positive film to be colored. The negative A is placed upon a suitable reel 11, facing outwardly thereon as indicated; thence threaded over a series of adjustably retardable rollers 12 and 13, each equipped with peripheral teeth for engaging the film perforations, under a rubber pressure roller 14, and around underneath a drum 15, also provided with teeth upon its periphery for engaging said perforations, leaving the apparatus over a roller 16, thence to a drying reel 17. The positive film B is placed upon a reel 18 adjacent a receptacle containing a chemical solution through which it is run for the purpose of moistening and softening the gelatinous coating thereon, sufficient to dissolve and absorb coloring matter from the negative film upon being subjected to a pressurable contact therewith, as will be hereinafter explained.

From reel 18 positive film B is successively carried over rollers 19, 20, 21 and 22, in the direction indicated by the arrows, the film being immersed in the solution 22^a in passing around roller 20, between rollers 19 and 21. From roller 22 it is brought into the contact apparatus C over a series of adjustably retardable rollers 23 and 24, similar to rollers 12 and 13, and likewise provided with peripheral teeth for engaging the film perforations, under rubber pressure roller 14, around underneath toothed drum 15, leaving the machine over roller 25, from which it may be carried to a drying reel or to another set of apparatus D, as shown in the drawing, should it be desired to subsequently apply one or more other colors.

In passing the two films over drum 15 they are carefully placed in register; that is, like views opposite each other with their gelatinous surfaces in contact.

Revolving drum 15 in the direction indicated by the arrow, by any suitable means, such as a crank 26 and drive shaft 27 actuating a worm and worm wheel secured thereto, draws the films A and B over rollers 12 and 13, and 23 and 24, respectively, as indicated by the arrows in Fig. 1.

It seldom happens that two films shrink the same after being wet in the developing process, and therefore it is necessary to stretch either one or the other longitudinally to bring them into perfect contact register for the transfer of the coloring matter. This is accomplished in drawing the films over retardable toothed rollers 12, 13, 23 and 24, by revolving the drum 15. Either

set of rollers being adjusted to exert a pull upon the film to stretch it the desired amount. It very often happens that a film, such as the positive film B in this case, stretches upon being wet, in which event rollers 12 and 13 may be adjusted to stretch the negative film A, as above described, to bring it into register therewith. Rollers 12, 13, 23 and 24, in addition to stretching the films to bring them to register, also serve to exert a tension to produce the proper contact pressure between them upon the drum 15, to facilitate in transferring the coloring matter.

Immediately after coming into contact with each other upon the periphery of the drum 15, the films A and B are subjected to an initial contact pressure by a soft rubber roller 14; this tends to a more perfect contact which is maintained throughout the osculation of the films upon the drum, and also serves to squeeze out excessive liquid that may remain upon the film.

In the absorption of coloring matter by the positive film from the negative through contact therewith, various lengths of time are required, varying from at least one minute to one and one-half minutes for best results; and for this reason drum 15 is adapted to revolve slowly to allow the films to remain in contact the required length of time in traveling between rollers 14 and 25.

This momentary film contact upon the revolving drum is a very essential feature of our process; not only as a means of producing perfect contact during a continuous and uninterrupted movement of the films, thereby resulting in a great saving of time, but also as affording the simplest and most efficient means of minutely gradating the depth or amount of coloring matter transferred to the positive print, merely by increasing or diminishing its speed of rotation to shorten or lengthen the duration of contact. Furthermore, such a means of contact insures the greatest protection to the moist gelatinous surface of the films, and the possibility of its being scuffed or loosened from its base by rough handling or sharp bending is entirely obviated.

It may be here stated that should it be desired to operate the drum at a constant speed, such as with motive power or the like, the duration of contact between the films may be altered by making roller 25 adjustably movable around the periphery of the drum, so as to shorten or lengthen the peripheral distance between it (the point of separation) and the point of contact on the opposite side.

This process is adapted to the application of one or more colors to a positive film by subjecting it to a pressurable contact with several negative films, each being a facsimile of the said positive and each carrying

a different color. To accomplish this several sets of the described apparatus may be set side by side in alinement with each other, as illustrated at C and D in Fig. 1, and the several negatives carrying the various colors placed on reels 11, and threaded through the machines as above described. The positive film may be carried continuously from one machine to the other as from C to D, as shown in Fig. 1, and operated as hereinbefore set forth.

The three primary colors, red, yellow and blue, are the ones most commonly used in the process, as it is with these that the greatest variety of natural tints may be produced. For instance, if it is desired to color the shrubbery in the views green, the positive film is run through two machines successively, each carrying a negative film; one with a coating of blue coloring matter and the other a coating of yellow, both upon corresponding portions of their views, and the two colors thus laid one upon the other, producing green. It can be readily seen that in this manner any number of colors may be applied to the various images in the views upon a positive film, by subjecting it to a contact with several negatives carrying the coloring matter.

By this process the coloring matter is evenly applied to the positive film, the outlines being clear and distinct, and the whole accomplished with a minimum of time and expense.

This application is companion to an application S. N. 132,351, filed on even date herewith, entitled machine for and art of coloring cinematographic films. In said application we claim the printing machine herein described and also the peculiar method of printing herein described which includes the feature of registration of the films; reserving to the present application claims which include the method of preparing the printing surface. Accordingly the following claims are directed to such a method; but it will be understood that the processes of such claims are not, except as therein specifically provided, limited to being carried on in association with the other features of the printing process that are claimed in said co-pending application. We have herein fully explained the whole composite process for the purpose of making our invention readily and clearly understood and not for purposes of limitation.

Having described our process, we claim:

1. The process of coloring cinematographic films, consisting of coating a positive print upon those portions of its views it is desired to color with matter impervious to light and taking a negative print therefrom, immersing such negative print in a chemical solution to render impervious to liquid all portions of the views exposed

to the light in printing, the subsequent immersion of such treated negative print in the coloring matter and the adhesion of such coloring matter to the portions thereof not rendered impervious thereto and the drying of such coloring matter thereon, the immersion of the positive print to be colored in a solution for the moistening and softening of the gelatinous surface thereon, subjecting the gelatinous surface of such positive print while moist to a pressurable contact with the gelatinous surface of the negative print carrying coloring matter, the views upon the positive print being made to register with the corresponding views upon the color carrying negative while in contact, substantially as and for the purpose herein set forth.

2. The process of coloring cinematographic films comprising uniformly blocking out with an opaque medium all those portions on a positive print which it is desired to color, making a negative from such positive, rendering insoluble all those portions of the negative surface exposed to light in making the negative, applying coloring matter to the portions which have not been exposed to light, and transferring such applied coloring matter to the film to be colored.

ALVIN WYCKOFF.
MAX HANDSCHIEGL.

Witnesses:
G. R. DEXTER,
WM. L. CONNORS.