

RESERVE COPY

[Second Edition.]

PATENT SPECIFICATION

Application Date : May 14, 1928. No. 14,124 / 28. 307,659

Complete Specification Accepted : March 14, 1929.



COMPLETE SPECIFICATION.

Improvements in Apparatus for Printing Kinematograph and like Films.

We, TECHNOLOR MOTION PICTURE CORPORATION, a corporation of Maine, United States of America, of 120, Brookline Avenue, Boston, Massachusetts, United States of America; and DANIEL FROST COMSTOCK, a citizen of the United States of America, of 80, Federal Street, Boston, aforesaid, do hereby declare the nature of this invention and in what manner the same is to be performed, to be particularly described and ascertained in and by the following statement :-

This invention relates to a method and apparatus for printing cinematographic films (or any other strips carrying a series of pictures whether motion or still) more particularly by imbibition.

The printing or stampings of images on blank films presents very exacting problems even in a single color but in printing or stamping pictures having a plurality of colors the problem is especially difficult to accomplish satisfactorily in actual practice.

For example, in producing cinematographic films in color by the imbibition of dye upon a film from one or more matrix films, where the images are to be printed in different or complementary colors in superposition (e.g. where one image represents the red (or red-orange) aspect and another represents the green (or blue-green) aspect of the scene) either on the same or on opposite sides of the film, the complemental images must be transferred and registered with an extreme degree of accuracy.

Among the problems encountered in the various operations involved are those of securing exact registration of the images and of minimizing or preventing the lateral spreading of the dye in any one color picture during the printing of another color picture. Moreover, when an attempt is made to print a series of pictures upon a continuous strip, as in cinematographic films, serious difficulties are encountered due to the character of the material employed. The film stock usually employed shrinks with age and as a result of the alternate wetting and drying incident to its development and use and varies in dimensions with temperature

[Price 1s.]

and humidity, while the gelatine coating on the surface which absorbs the dye swells appreciably when wet. The difficulties from this source are further increased by the fact that the pictures are arranged in sequence upon a long strip of such material from which they are printed upon another strip of like characteristics. Moreover, the images upon the finished film are greatly magnified to many times their printed size when projected upon a screen and this causes any defects due to imperfect registration to be correspondingly exaggerated. Therefore it is absolutely essential in order to have a satisfactory transposition that the strips be brought into substantially perfect registration at the time of contact and then so maintained for a substantial period of time or through a relatively long path during which the transposition of the dye (from the wet portions of the matrix corresponding to the images to be transferred therefrom) to the blank is effected.

The present invention presupposes the use of either a single matrix film or for color printing a plurality of matrix films corresponding to the several colors to be employed, and a blank film upon which the reproduction is transferred from the matrix film by imbibition. The method of the invention includes broadly the steps of impreganting the matrix or printing film with a suitable dye solution, removing unabsorbed liquid from the surface thereof, bringing the dye-wet surface of the matrix film into predetermined, uniform and intimate contact with a previously wet film blank to be printed (preferably effecting such contact at a point where both films are thoroughly immersed in a liquid) simultaneously or successively registering the blank and the film with each other and with a backing strip of relatively permanent and predetermined dimensions (such as a continuous metallic belt) causing the belt and films in registered association therewith to pass through an extended path (i.e. one requiring a sufficient time of traverse to permit complete imbibition of the dye from the matrix film to the film blank) followed by successive or simultaneous

Price 5s. 0d. /

Price 4s. 6d.

Price 3s. 6d.

separation of the films and backing strip and drying in readiness for use, or, in the case of making multi-colored reproductions, passing the thus printed film blank through a second series of steps substantially identical with and controlled or synchronized to proceed in step with the first.

The matrix film is continuously withdrawn, after separation from the film blank and metal backing, passed through a "decroceinating" solution, that is to say a solution for removing the dye and dye solution completely therefrom and leaving the film in suitable condition for subsequent re-use. It is then passed through washing and drying chambers preferably under regulated tension and at a regulated speed conveniently imparted to it by winding upon a positively driven winding drum, which may in turn be controlled and regulated by the effective tension of the film. As thus gathered on the reel the film may be returned to the entrance end of the machine for re-use as before.

The apparatus of the invention includes the sequential arrangement of means for effecting the printing of films by imbibition, generally comprising means for wetting or dyeing a matrix film, means for wetting the blank film to be printed, means for effecting intimate contact between the appropriate surfaces of the films (preferably while submerged in a liquid), means for registering said films with respect to each other, backing means for conveying the thus registered films in undisturbed contacting relationship through a prescribed path (such as a continuous metal belt), means for pressing said films together and against the backing, means for conveying the same in such contacted relationship through an extended path, by means of the backing under controlled and predetermined conditions, means for subsequently separating and drying the printed film, means for separating, decroceinating, rinsing and drying the matrix film and means for guiding the metallic belt to the origin of its circuit. Means are likewise provided for conveying the matrix and blank films (after separation from the backing) through the apparatus at a suitably regulated rate of speed, so controlled as to provide uniform movement and tension upon the film without disrupting or wearing the same or permitting it to become slack. Means also are included whereby two or more successive printings upon the same film blank may be effected in a continuous sequence of operations.

A typical adaptation of my invention will be described with reference to the

printing of two-colored reproductions upon transparent cinematographic films, a specific embodiment of the apparatus therefor being shown in the accompanying drawings, in which:

Fig. 1 is a general side elevational view showing one of two units arranged in parallel;

Fig. 2 is a diagrammatic view similar to Fig. 1 but showing both units (for printing with red and green dyes respectively) as though arranged in superposed parallelism, the unit for red dyeing (R) or forward unit as viewed in Fig. 1, being raised above that for green dyeing (G);

Fig. 2a is a fragmentary detail view showing the pin belt, films and pressure rolls in longitudinal section;

Fig. 2b is a transverse section of the films and belt;

Fig. 3 is a fragmentary detail view of the right-hand section of the red-dyeing apparatus as viewed in Fig. 1;

Fig. 4 is a fragmentary elevation, including and continuing from the left-hand side of Fig. 3;

Fig. 5 is a longitudinal vertical section of the rear or green dye tank as viewed from the rear with respect to Fig. 1;

Fig. 6 is a cross section of both the red and green dye tanks in the plane of line 6-6 of Fig. 5;

Fig. 7 is a longitudinal vertical section of the front or red dye tank as viewed in Fig. 1;

Fig. 8 is an end elevation of both tanks from the right-hand side of Fig. 7 (or Fig. 1);

Fig. 9 is an enlarged longitudinal vertical section of the water tank or contact chamber as shown in Fig. 3;

Fig. 10 is an end elevation viewed from the right-hand side of Fig. 9;

Fig. 11 is a cross section and view on line 11-11 of Fig. 9 in the direction of the arrows;

Fig. 12 is a view on line 12-12 of Fig. 4;

Fig. 13 is an end view of a nozzle;

Fig. 14 is a vertical section through Fig. 13;

Fig. 15 is a plan view of the heating coils;

Fig. 16 is a side elevation of Fig. 15;

Fig. 17 is a view on line 17-17 of Fig. 16;

Fig. 18 is an enlarged detailed section along line 18-18 of Fig. 17;

Fig. 19 is an end elevation of one unit from the right-hand side of Fig. 15;

Fig. 20 is a detailed vertical section on line 20-20 of Fig. 19;

Fig. 21 is an enlarged fragmentary view of elements indicated in Figs. 1 to 4 including the decroceinating and rinse

70

75

80

85

90

95

100

105

110

115

125

130

tanks, the drying conduit and water removing device;

Fig. 21a is a fragmentary plan view of the drying conduit;

5 Fig. 22 is a plan view of the suction or water removing device;

Fig. 23 is a side view of Fig. 22;

Fig. 24 is a section on line 24—24 of Fig. 22; and

10 Fig. 25 is a longitudinal section through one of the pulleys in the dye tank over which the matrix moves.

Referring to the drawings (Figs. 1 and 2) the apparatus illustrated includes two units (R and G) arranged in substantially parallel relationship for the continuous, successive printing of a blank film strip first with a red dye (R) and then with a green dye (G) thereby producing a complete color reproduction on the surface of the completed film. Fig. 1 shows a side elevation of the apparatus, the red-dye unit (R) being in front, while in Fig. 2, which is diagrammatic only, the red-dye unit (R) is raised to disclose the green dye unit (G) therebehind and the parallel relationship of parts and orderly sequence of operations in the two units.

The red-dye unit (R) comprises generally a relatively extended structure 1, and means associated therewith for bringing the film to be printed 2 into intimate contact with the red-printing matrix film 3 and conveying the films in contact through an extensive path, means for separating the printed films and passing the film to be printed 2 to the green-dyeing unit (G) comprising a structure 4, which is arranged parallel to and is substantially identical with the structure 1, and means for effecting like contact with a green-printing matrix dye 5.

The unit (R) includes means for wetting the blank film to be printed, such as a long water tank 6 and means, such as dye tank 7, for wetting and dyeing the matrix film. Means are also provided for effecting an accurate and predetermined contact between the dye wet matrix and water wet film blank, including a water tank 8, provided with guide pulleys 9 and 10, adapted to receive the continuous metal belt 11, and also the films 2 and 3, therebetween. The belt 11 is preferably a thin and flexible but resilient strip or belt, conveniently made of non-corrosive and non-corrodable metal such as tin-plated steel. The pulleys 9 and 10 have rubber covered peripheries grooved to receive the heads and ends respectively of the pins 11¹ (Figs. 2a and 2b). For example, the strip may be approximately .005" thick with a .001" coating of tin on each side. Straight-sided projecting pins 11¹ are arranged at accurately spaced intervals and in accu-

rately parallel rows along the longitudinal margins of the strip but slightly spaced from the edge (Figs. 2a and 2b). The pins are preferably rounded at the top but have stright, substantially parallel sides, especially adjacent to their lower ends. The pins may be welded or soldered to the back of the belt (Figs. 2a and 2b). The belt 11 is carried through a closed circuit over a pulley 12, of larger diameter at the opposite end of the unit and internally contacting pulleys 13 and 14, and under pulley 15 (positioned in tank 8) which engages the exterior side of a belt. The pins may fit the sprocket holes in both dimensions or the pins of one row may fit longitudinally of the film and the pins of the other row transversely of the film.

Means are provided for separating the printed film from the film matrix 3 and belt 11, including pulleys 190 and 191 and for removing the film matrix 3 from the belt 11, such as pulleys 16. Means are also provided for treating the separated films for decroceinating, rinsing, drying and reeling the same, ready for re-use. These means in the illustrated embodiment comprise in series below the machine and extending substantially throughout its length a decroceinating tank 17, a rinsing tank 18, a horizontal drying chamber 19, and a vertical drying chamber 20.

The second unit G (in which certain of the like parts are indicated by like numerals primed) has a wetting tank 6¹, for the printed blank film 2 from the unit R, and a dye-tank 7¹ (Figs. 2 and 5) for the green-dyeing matrix film 5, followed by rollers 22 conducting the film through a supplementary tank 23, having water showers 24 positioned thereabove with valves 25 (Fig. 3). These tanks are followed (Fig. 2) by a contacting chamber such as water tank 8¹, with pulleys 9¹, 10¹, 12¹, 13¹, 14¹, 15¹ respectively for the endless belt 11¹—substantially identical with those described with reference to unit R,—and also decroceinating and rinsing tanks 17¹, 18¹, and drying chambers 19¹, 20¹ respectively.

In the drying chambers 20, 20¹ automatic means for tensioning and taking up the matrix films are installed, such as the positively driven reels 26, 26¹ for taking up the dried matrix films 3 and 5, and tension weights 27, 27¹ are suspended by pulleys upon free loops of the film. Carrier reels 30 and 30¹ are mounted upon the common bracket 31, at the inlet end of the units R and G for feeding the matrix films to the apparatus. A supply reel for the blank film to be printed is mounted at 320 and a take-up reel at the end of the apparatus at 321. Above the matrix reels 30 and 30¹ similar reels (showing the hubs 130

- only, Fig. 3) may be mounted for carrying a film to succeed the matrix film in use,—having brake mechanism (which is similarly provided on reels 30, 30¹ but not shown) comprising a lever 32 having one end 33 bearing upon the periphery 34 of the reel hub and the other end having a spring 35 carried upon an adjusting pin 36.
- 5 The unit R (Fig. 3) includes means for effecting the progressive and continuous wetting of the matrix film from reel 30 (with a red dye solution) such as a pulley 37 and tank 7 having an outer shell 38 constituting a water jacket surrounding both the inner red dye vat 39 of unit R and inner green dye vat 40 of unit G (Figs. 3, 5, 6, 7 and 8).
- 10 The jacket 38 rests upon longitudinal angle irons 42 while the dye tanks 39 and 40 are suspended by flanges 44 at their upper edges upon angle irons 42a which are parallel to and above the first pair. Both pairs of angle irons are in turn fixed to the vertical uprights 43. Above the flanges 44 are provided L-shaped supports 45, 45¹, each having horizontal members 46 resting upon flanges 44 and vertical members carrying bearings for a series of pulleys 47. A similar series of pulleys 47a opposite and offset with respect to the first are mounted in the lower part of each tank. Each pulley (Fig. 25) has a cylindrical surface 49 and end flanges 50 with intermediate guides 51 adapted to receive and support the edges of a film passing thereover. Each pulley is mounted at the ends upon bearings 52 having conical points 53 which are received in conical recesses 54 upon the ends of the pulley axis 55 and held in adjusted position by set-screws 56. Similar pulley construction may be used in other parts of the apparatus.
- 20 The outer jacket of the tank 7 is connected to a suitable supply of water through pipe 57 controlled by valve 58, outlet 59 controlled by valve 60, and an overflow outlet 59a. Red dye tank 39 is likewise provided with an inlet 61 having valve 62, and an outlet pipe 64 controlled by valve 65 and overflow outlet 63. A supplementary drain 66 and valve 67 serves to withdraw the dye when it is to be discarded. Pipes 61, 64 and 66 pass through the wall and into tank 39 and are suitably joined by washers and nuts 68, 69 and 70. Green dye tank 40 is provided with similar connections (Fig. 5) 61¹, 62¹, 63¹, 64¹, 65¹, 66¹ and 67¹ respectively.
- 25 At the exit end of tank 39 (Figs. 1, 3 and 7) nozzles 71 leading from compressed air line 72 are mounted on either side of the matrix film 3 which is carried upon pulleys 73, 74 and 75 located in conduit 48 and passes between a pair of inwardly directed water nozzles 76, 77 (Fig. 11). The latter are connected through pipe 79 to the main pipe line 78 which supplies the water tank 8. The nozzles 76 and 77 (Fig. 11) terminate in restricted openings 80, 81 having a conical wall 82 and horizontal aperture 83 (Figs. 13, 14). The nozzle 76—80 passes through housing 84 which has an opening 86 opposite nozzle 81 to catch the water therefrom and an exit pipe 87. Nozzle 77—81 passes through housing 85 which has a similar opening 89 therein opposite nozzle 80 and an exit pipe 90. Exit pipes 87 and 90 lead through the common outlet 88.
- 30 Means for effecting registry and contact between the films 2 and 3 and metal band 11 consist of a pulley 91 in the tank 8, a pair of opposed compression rollers 92 and 93, (Fig. 9), the upper roller 92 being mounted in bearings 95 received in vertical guides 94 and provided with counterweights 96 received upon the upright spindle 97, and a second pair of compression rollers 10 substantially identical with the first except that the upper roller is fitted with a belt 98 passing over an offset roller 99 mounted on the arm 100. The water tank 8 in which these elements are mounted is also provided with an inlet supply 101, an overflow outlet 102, and a drain pipe 103.
- 35 At the end of tank 8 is provided an exit aperture 104 (for the superposed films 2 and 3 and metal band 11) leading to the adjacent chamber 105 (Fig. 3) through an enclosing gate 106 which is followed in succession by a pair of rollers 107, 108,—(the latter being mounted on lever 109 and pressed toward the other by compression spring 110 adjusted by screw 111)—a belt 112 passing over roller 109 and also over supplementary rollers 113 and 114, and additional pairs of compression or guide rollers 107a—108a, 107b—108b. The chamber 105 is provided with drainage outlets 174. Extending from chamber 105 is provided a guideway 116 (Fig. 4) consisting of an angle iron framework and an enclosed conduit thereon, leading to the pulley 12 (Fig. 2) and returning to the entrance end of the unit (Figs. 1—2). The first section of this guideway or conduit is left open and provided with electrical resistance heaters consisting of resistance elements 117 mounted in sheets of mica 123 (Figs. 17 and 18) by means of spaced uprights. The latter consist of L-shaped horizontal pieces 118 fixed to the guideway 116 (Figs. 16 and 17) by screws 119, and vertical members 120 having slots 121 for bolts 122 passing therethrough and adapted to support the vertical sheets of mica or other
- 40
- 45
- 50
- 55
- 60
- 65
- 70
- 75
- 80
- 85
- 90
- 95
- 100
- 105
- 110
- 115
- 120
- 125
- 130

insulation 123 upon which the resistance elements 117 are supported by being passed through insulated apertures 125, and held in extended position by insulated terminal lugs 126, screw-threaded sleeves 127 and connections 128 leading to a suitable source of electric current. The heating unit and also the guideway or conduit 116 and associated parts are conveniently mounted upon an angle iron framework 129 and support 130 (Figs. 12 and 16).

Extending from the heating zone is provided an enclosed circuit corresponding to the path of the belt 11, formed by the guideway 116 made up of a series of enclosed chambers, comprising the upper chamber 131 (Fig. 12) having a cover 134, a lower chamber 132 separated from the upper chamber by plates or partitions 136, with pipes 133, leading into chamber 132 for circulating a cooling or heating medium such as water therethrough. The guideway 116 thus formed (Fig. 4) is followed by decroceinating tank 17 (for the matrix film 3) having entrance pulley 16 and exit pulley 137 (Fig. 21), a succeeding pulley 138, and a rinsing tank 18 with entrance and exit pulleys 139, 140, both of tanks 17 and 18 being provided with water inlet and outlet connections 141 and 142.

At the exit from tank 18 there is provided a blowing device 144 (Figs. 21—24) mounted on bracket 145 having guide rollers 146 on spindles 147 fixed by screws 148 to the casing which contains a chamber 149 closed by a plate 151, having a central opening 152 for connecting to a source of compressed air (not shown). Intermediate of the pulleys 146 and on opposite sides of the film 3 are provided a pair of tubular chambers 154 fixed to the plate 151 by screws 153, 155, each of said chambers opening (at 156) into chamber 149 and being connected by a pair of parallel transverse tubes 159 spaced apart to permit the passage of matrix film 3 therebetween, each of the tubes 159 opening into the chambers 154 at both ends 160. The transverse tubes 159 have longitudinal slits 162 in opposed relationship and directed at an angle to the opposed faces of the film 3. The blower 144 is followed in succession by drying chambers 19 and 20 (Fig. 1) which have already been described.

The pulleys 14 and 14¹ (Figs. 9 and 10) for carrying the endless belts 11 are mounted upon uprights 164, which in turn are slidably mounted in vertical guideways 163 and tend to be moved upwardly by the force of weights 165 (Fig. 3) attached to the ends of the cord 166 which is passed over a fixed pulley.

For receiving the printed film blank 2 a longitudinal conduit 167 (Figs. 21 and

21a) is provided which has air inlets 171, 172 from a blower hood 170, extending past the entrance chamber to decroceinating tank 17 (Fig. 3) and opening into the end of conduits 167—167¹ (adjacent to the pulleys 190, 191 for conveying the film) which open at their farther ends into chambers 20, 20¹, respectively. The conduits are provided with windows 172¹ (Fig. 21) through which the films may be observed.

The heating unit, guideways, blowing device, decroceinating tanks, and driers have been described with reference to the single sequence of apparatus and parts which is generally designated R in Fig. 2 and arranged for the printing of the blank in red dye, but as will be readily apparent from the drawings, such parts are shown in duplicate, the elements of the second series being substantially identical with those of the first, for effecting the printing of the blank in green from the green matrix as already indicated and herein-after to be described. The corresponding parts of the second series of elements are indicated by the same numerals as those of the first, but primed.

As a preliminary step to the operation of the apparatus it is necessary to fill the water tanks 6 and 6¹ and provide a constant circulation of fresh water, preferably maintained at constant temperature therethrough by means of the water pipes 175. It is also necessary to fill tanks 8, 8¹ with water and assure a constant flow through openings 101 and outlets 102 (Fig. 9). The water bath of the dye tank 7 is likewise adjusted and the valves 25 to the water showers 24 and valves (not shown) controlling the water nozzles 76, 77 are opened.

Compressed air is let into pipe 72, and an electric current passed through heating coils 117, if required.

An air pressure of suitable proportions is set up and maintained in the system connected to the openings to the chamber 149, and a hydraulic pressure through inlets 133 to chambers 132. The latter may be connected to a preheated or pre-cooled supply of water for the purpose of circulation, through chamber 132, to more accurately control the temperature conditions during the imbibition, and likewise the water to tanks 6 and 6¹ may be pre-conditioned. The water in tank 8 is also preferably heated or otherwise treated to expel dissolved gases.

In the practice of the method of the invention by means of the apparatus thus illustrated and described, the (red-dyed) matrix film 3 contained upon the reel 30 is first set in place on bracket 31 and the film passed over pulley 37 and thence alternately over the upper and correspond-

5

10

15

20

25

30

35

40

45

50

55

60

65

70

75

80

85

90

95

100

105

110

115

120

125

130

ing lower pulleys 47 in the dye tank 39, over pulley 73, over pulleys 74, 75 in conduit 48, and downwardly and under pulley 91 where it is brought into contact and registry with the upper surface of the continuous belt 11. Here the usual sprocket holes in the margin of the film are passed over a corresponding series of projecting pins provided along the marginal edges of the latter already described.

In passing over the pulleys here employed, the film or composite strip, as the case may be, engages the annular shoulders 51 (Fig. 25) thus leaving both sides of the intermediate portion of the faces of the strip open to free contact with the surrounding medium (liquid or gaseous) but out of contact with the solid parts of the apparatus.

The belt 11 is characterized by being longitudinally non-extensible but flexible and provided with means (such as the projecting pins already mentioned) for engaging the matrix film as well as the film to be printed.

The belt 11, with the end of film 3 contacting therewith, is next advanced under the pulley 91. Film 2 from reel 320 is then led through tank 6 downwardly over suitable pulleys and into contact with the matrix film 3, the pins upon the flexible belt 11 projecting through the sprocket holes of matrix film 3 being sufficiently long to engage the sprocket holes in the blank film 2. The thus contacting belt 11, matrix film 3 and blank film 2 are next advanced between the pair of compression rollers 9, thence between the second pair of rollers, 10, the belt 98 being of such width as to enter between the marginal pins provided upon the flexible belt 11 and to thus force the films into intimate contact with each other, this intimate contact tending to be subsequently preserved by the friction of the margins of the sprocket holes in the films upon the pins of the metal belt upon which they are impaled.

The composite strip is now passed through aperture 104 into chamber 105 in which it passes between compression rollers 107—108, 107a—108a, 107b—108b (Fig. 3), thence over heating unit 117 and between rollers 107c—108c (Fig. 16) and from there along or through the path defined by conduit 116 passing over the larger pulley 12 at the opposite end of the apparatus and back to the entrance end. Here the film blank 2 is separated from the belt and matrix film 3 by passing over pulleys 190, 191, and through conduit 167 to drying chamber 20. [It may be reeled at this point, or, as shown by Fig. 2 passed thence over suitable pulleys, to and through water tank 6¹ and thence through a substantially identical path in the second

or green-dyeing unit of the apparatus, in contact with the green-dyeing matrix film 5 and finally to gathering reel 321.]

The matrix film 3 is separated from the belt by passing over pulleys 16, thence into the decroceinating bath 17, under pulley 137, over pulley 138, under pulleys 139 and 140, and thence over the first pulley 146 between the air jets from tubes 159 (Figs. 22, 24) over the upper pulley 146 and thence through the horizontal drying chamber 19 and into vertical drying chamber 20, suitable pulleys being provided as indicated in Fig. 2. Weights 27 are suspended also by means of floating pulleys upon freely depending loops of the film between the fixed pulleys in drying chamber 20 to maintain constant tension thereon. The film is finally gathered upon reel 26.

The flexible belt 11 returns to the starting point under pulley 13, passes over the upwardly tensioned pulley 14 and under the pulley 15 in water tank 8.

A suitable red or red-orange dye solution is now supplied to dye tank 39 (after threading and adjusting the printing matrix film and blank film through the apparatus as has just been described) by opening valve 62 and subsequently adjusting the same so as to maintain a slight overflow at 63 which may be re-used after adding enough dye to assure uniformity. The green dye tank 40 is likewise filled with an appropriate green dye solution which is thereafter circulated in a similar manner by adjusting valve 62¹.

The belt 11 is now driven through the described circuit by positive actuation of the pulley 12. Suitable driving mechanism is also provided which may be advantageously synchronized with pulley 12 for gathering up the matrix film. The latter may be controlled, for example, by movement of the suspended weights 27.

The printed film 2, after leaving the belt 11, may be drawn through its subsequent path through the apparatus by separate means of any suitable sort, if one color only is to be imprinted thereon, or, as in the present instance, may be passed directly to the second or green-dyeing unit and drawn therethrough by the normal operation of the apparatus in the same manner as in the first operation which has just been described and finally rolled up upon reel 321.

When operated in this manner the film blank 2 is continuously drawn through the water tank 6 and thus thoroughly wetted. This tends to soften and also to slightly swell the gelatinous substance of the film which also promotes its susceptibility to the wetting and absorptive characteristics with respect to dye solutions. Accord-

70

75

80

85

90

95

100

105

110

115

120

125

130

ingly it is substantially uniformly wet and saturated with water before it enters the water in tank 8.

5 The matrix film is drawn from reel 30 under slight tension, produced by the friction of brake mechanism 33, over pulley 37 and thence downwardly and upwardly through the red-dye solution in tank 39. By providing an extended path through this solution, the matrix is thoroughly and uniformly contacted therewith. Due to the surface characteristics of matrix films, however, the dye is adsorbed upon the respective areas of the film substantially to correspond to the degree of development thereof. Upon leaving the tank any loosely adhering dye solution is effectively removed by a blast through nozzles 71 which open adjacent to the opposite faces of the wet film. The film then passes through conduit 48 and downwardly between the opposed jets of water from apertures 80 and 81 which thoroughly rinse the film and wash off all of the dye solution except that which is specifically adsorbed in accordance with the nature of the surface and developed structure (physical or chemical) thereof which remains associated with the matrix film in proportionate distribution. The film then passes downwardly into the water in tank 8.

By the submersion of the matrix and blank films in water (or other suitable liquid) the wet condition of their surfaces is maintained, (as well as of the dye upon the matrix film) and at the same time any entrained or adsorbed air or air bubbles are removed. The matrix strip and blank film may be further cleansed by a jet of fresh water from nozzle 400 (Fig. 9) which agitates the water in tank 8. The surfaces are thus conditioned for effectuating an intimate and uninterrupted contact therebetween which is especially desirable or necessary for satisfactory imbibition. Accordingly, when the belt 11 with matrix film 3 is advanced and blank film 2 brought into registry and contact therewith, and the three strips are carried thence between pressure rollers 9, 10, they are separated only by a continuous film of water which is progressively expelled by the compression applied by the rollers. The wet matrix film and impregnating stratum of dye thereon effects an intimate wetting contact with the film blank such that the dye may be substantially completely transferred to the latter by selective imbibition (i.e. during the subsequent period of traverse of the belt during which such contact between the film surfaces is maintained).

To further perfect this contact, the belt and films pass under the belt 98 which fits

between the marginal rows of pins on the belt 11 and progressively forces both films firmly downward over the pins and against the unyielding backing of the belt. As already mentioned, the resulting friction between the pins and sprocket holes of the films effectively retains this relative disposition of the three strips, which then pass out of the water tank 8 through aperture 104. At this point some leakage of water is certain to occur, but this is removed through drains 174.

Upon now passing between the spring compressed rollers 107—108, 107a—108a, 107b—108b, the strips are still further compressed and then guided to pass over the heating elements 117 (Fig. 16). The heating elements may be operated or not, as desired, depending upon the nature of the dye solution, temperature and humidity conditions, and like considerations affecting the condition of the films.

The strips pass between rollers 107c—108c (Fig. 16) and then into and through the conduit 116 supported by plates 136 which in turn rest upon the side walls, the intermediate portion being preferably maintained at a substantially constant temperature, due to the transmission of heat through plates 136 to or from a current of cold water which may be circulated through passages 132.

At the end of the first run of conduit 116 the combined strips pass over driving wheel 12 and thence back through the return of conduit 116 to the pulleys 190, 191. The length of this run is so determined with respect to the operating conditions and the properties of the film, dye, etc., that by the time this point is reached, the originally blank film has substantially completely imbibed the dye from the matrix film and is also sufficiently dry to permit separation therefrom without any tendency for the dye to be redistributed through the film or to be disturbed in the relative values in which it appears upon the film surface.

The matrix film 3, which may retain small quantities of dye in its printing areas or in the sprocket holes, is separated from belt 11 by pulleys 16, and then passes through a decrocinating tank 17, so-called, containing a solution of alcohol and ammonia, for example, which rapidly and completely removes such traces of dye from the film. It is then withdrawn by passing over rollers 137, 138 and 139 and passed through rinsing tank 18 containing a constant circulation of fresh water, and thence sent between blasts of air from the opposite slits 162 of blower 144 which effectively wipe off surplus water, the adsorbed water being dried off upon passing

70

75

80

85

90

95

100

105

110

115

120

125

130

through the drying chamber 19 and through the vertical dryer 20. In the latter a plurality of vertical runs are provided to form an extended path, one or more free loops being left in which loose pulleys and weights 27 are suspended which serve to take up and modify the effective tension upon the film throughout the earlier stages of its travel through the apparatus. It is then gathered upon reel 26 which, as already indicated, may be synchronized with the wheel 12 or by the tension and movement of the weights 27, or both. As thus treated, the matrix film is dry so that it may be safely reeled without danger of sticking and substantially entirely free from adhering dye and ready for re-use even after it has been passed through the dyeing and printing steps many times.

Returning to the blank 2, which has now been printed with the red aspect of the final reproduction to be imparted thereto. This film may be passed between air blast nozzles (177) and thence over pulley 191 (Fig. 3) to the extended horizontal drying chamber 167. Here the film passes in the same direction as the current of air from blower 170 finally emerging into dryer 20 through which it may pass. Of course, if only one color is to be used, it is now finished, but ordinarily it is necessary for effective results to print it with one or more different colors. To this end it may be conveyed to and through the water tank 6¹ of unit G which again wets it thoroughly, though probably slightly more in the unprinted portions and in those areas in which light shades or tints only have been produced than in the heavily printed parts.

The film is then returned to the entrance end of the unit G (Fig. 2) where it is immersed in water contained in tank 8¹ where it is contacted with the green matrix film 5. In this unit the matrix film 5 passes from reel 30¹ through green dye tank 40 and thence in vertical runs over pulleys 22, in tank 23 (Fig. 5) before passing through conduit 48. Each run is provided at the top with a water shower 24 which floods the film immediately below it and thus removes excessive and non-uniform accumulations of dye, the wash water draining off at the bottom. Alternatively the tank 23 may be filled with water which is circulated therethrough. The film 5 then passes through conduit 48 and downwardly into tank 8¹ where it engages the belt 11 and comes into contact with and is accurately registered with the blank film 2 so as to coincide with the complementary images already printed thereon.

After passing through a like procedure to that already described with respect to the red dye (but in which certain changes may be made such as omitting the operation of the heating unit, etc.) the matrix film is drawn through the decroceinating tank 17¹, rinsing tank 18¹, horizontal dryer 19¹ and vertical dryer 20¹ and reeled up at 26¹ ready for repeating the operation by returning the reel to bracket 31. The printed film is now gathered upon reel 32¹ after drying and is ready for use in the usual cinema apparatus for the projection of colored motion pictures.

After being once "threaded" and used in the manner described, the apparatus may be kept in readiness for immediate operation by attaching a blank film or perforated brass strips to the end of the matrix film and to the end of the film to be printed which are drawn through the apparatus thus forming a continuous strip throughout the entire length of the unit when the end of the matrix has reached the gathering reel 26. The same may be done in the green unit.

Upon now starting the mechanism it is only necessary to attach the end of the new matrix film to the end of the metal strip, attach the fresh blank film to the other strip and pass the strips through the apparatus in the manner described. This draws the matrix and blank films completely through the apparatus. The metal strips are then removed from the reels upon leaving the machine and the matrix and printed films are attached to their corresponding reels which continue to draw them through the apparatus in the prescribed manner.

If two successive but different matrix films are to be used for printing, the second may be directly attached to the first and a fresh blank film attached to the end of the first blank film and the operation conducted continuously. Such operation will practically require that the same dye solutions shall be suitable for use upon both films although it is conceivable that the dye tanks might be removed and replaced with others threaded with the new matrix and that such interchange might also be effected with respect to the green dye tank.

From the foregoing it will be evident that this unique method of interlocking the films against relative movement permits the films to be flexed while held in registered relation to each other so that they may travel to and from rollers or drums or along rectilinear paths, that is, approximately straight paths or non-rotary paths, while interlocked in registered contact.

Having now particularly described and ascertained the nature of our said invention, and in what manner the same is to

be performed, we declare that what we claim is:—

5 1. Apparatus for printing a cinematographic or like dye-absorbent film from a matrix strip by imbibition (dye absorption) from the strip to the film, having mechanism for bringing the film and strip into face contact and pressing them together, characterized by registering pins 11¹ for
10 holding the films against relative movement while in face contact, the pins being mounted on a flexible strip such as the matrix strip or preferably a separate metallic backing 11 to permit the film and
15 strip to travel along either a straight or a curved path while in face contact.

20 2. Apparatus according to claim 1 further characterized in that the backing is in the form of an endless belt traversing an endless path along a part of which the film and strip are held in face contact as aforesaid.

25 3. Apparatus according to claim 1 further characterized in that the strip and film are fed from the backing at successive locations along the path of the backing.

4. Apparatus according to claim 1

further characterized by means for controlling the temperature of the film and strip while in face contact.

5. Apparatus according to claim 1 further characterized in that the strip and film are brought into intimate face contact while submerged in a liquid medium.

6. Apparatus according to claim 5 further characterized by means for agitating the liquid where the strip and film are brought into contact as by a jet of fresh water from nozzle 400 (Fig. 9).

7. Apparatus according to claim 1 further characterized by means (such as perforated belt 98 as in Fig. 9 or 112 as in Fig. 3) for pressing the film and strip together intermediate the sprocket holes.

8. Apparatus according to claim 1 further characterized by suction openings (such as shown at 83 in Figs. 13 and 14) for removing the liquid squeezed from between the film and strip.

Dated the 14th day of May, 1928.

WM. BROOKES & SON,
London & Lancashire House,
5, Chancery Lane, London, W.C. 2,
Chartered Patent Agents.

[This Drawing is a reproduction of the Original on a reduced scale.]

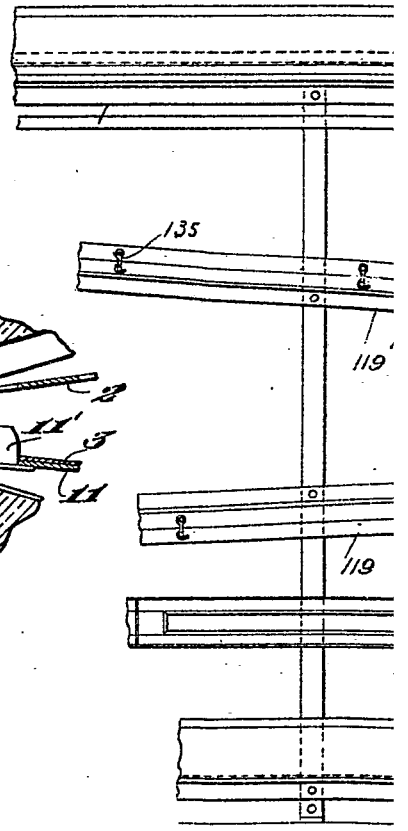
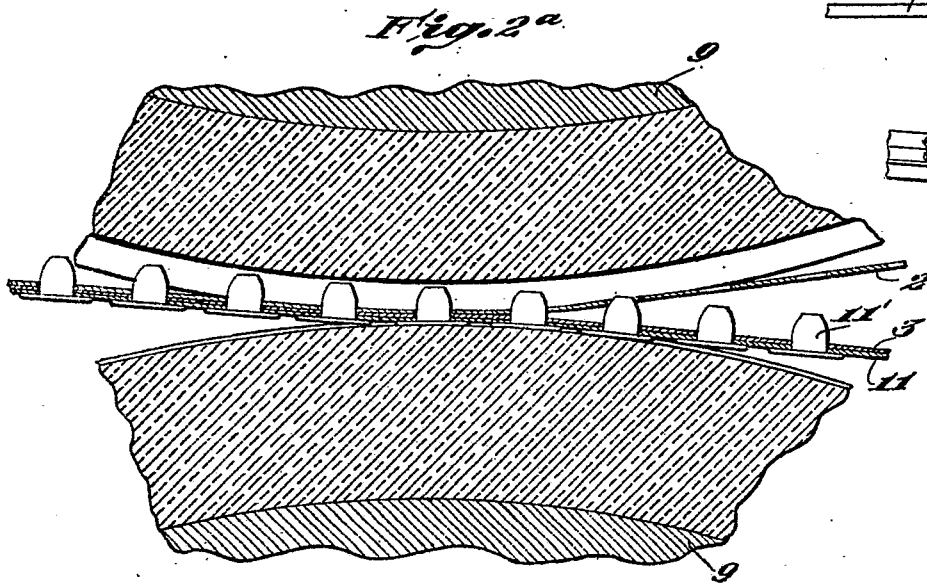
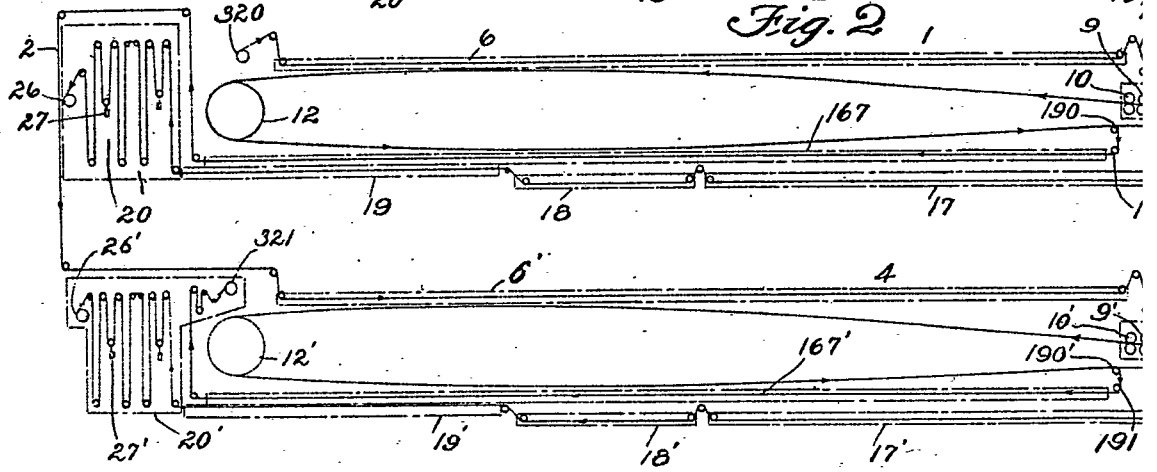
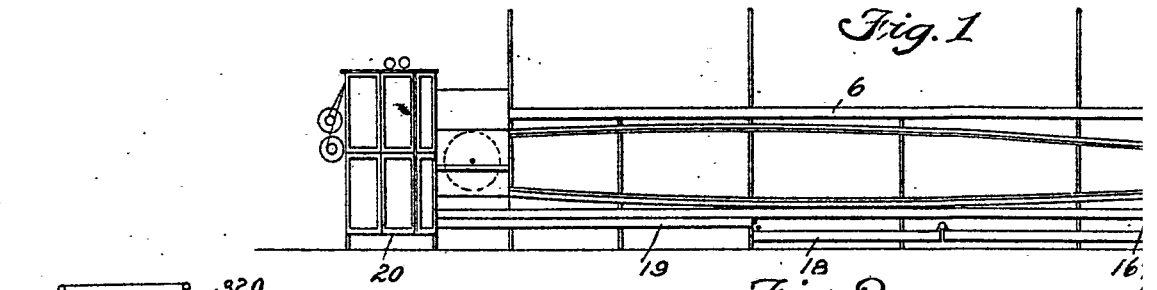

Fig. 1

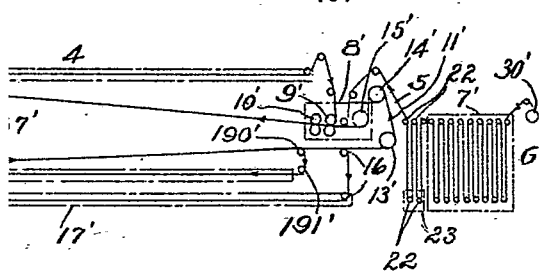
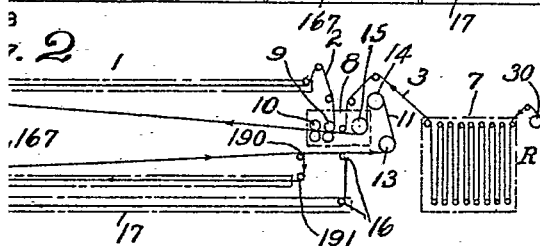
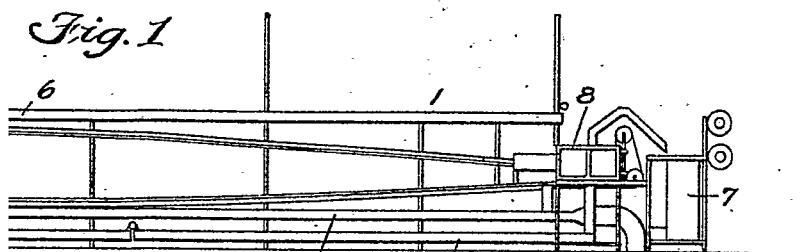

Fig. 2^b

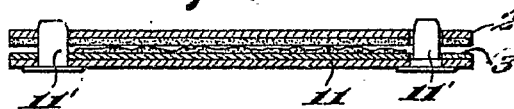
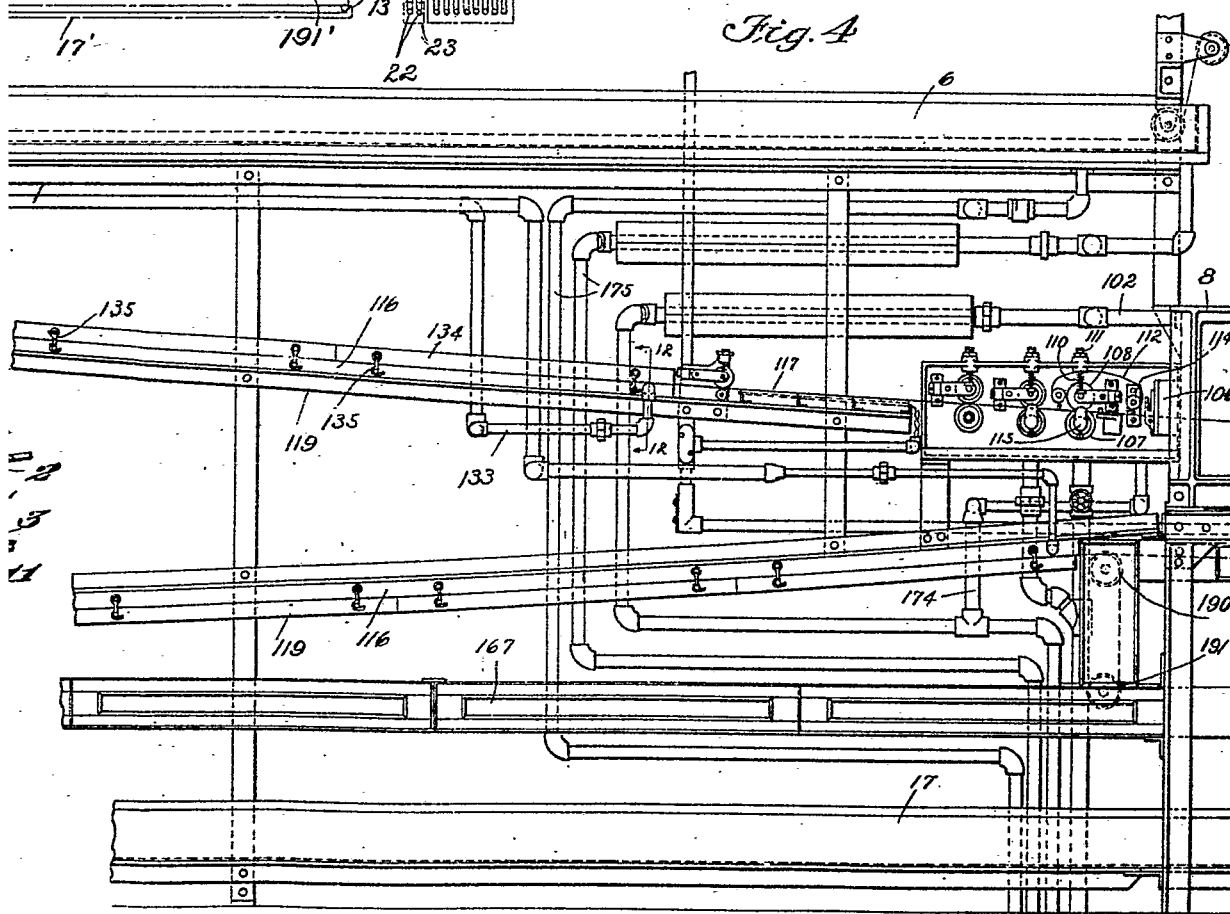
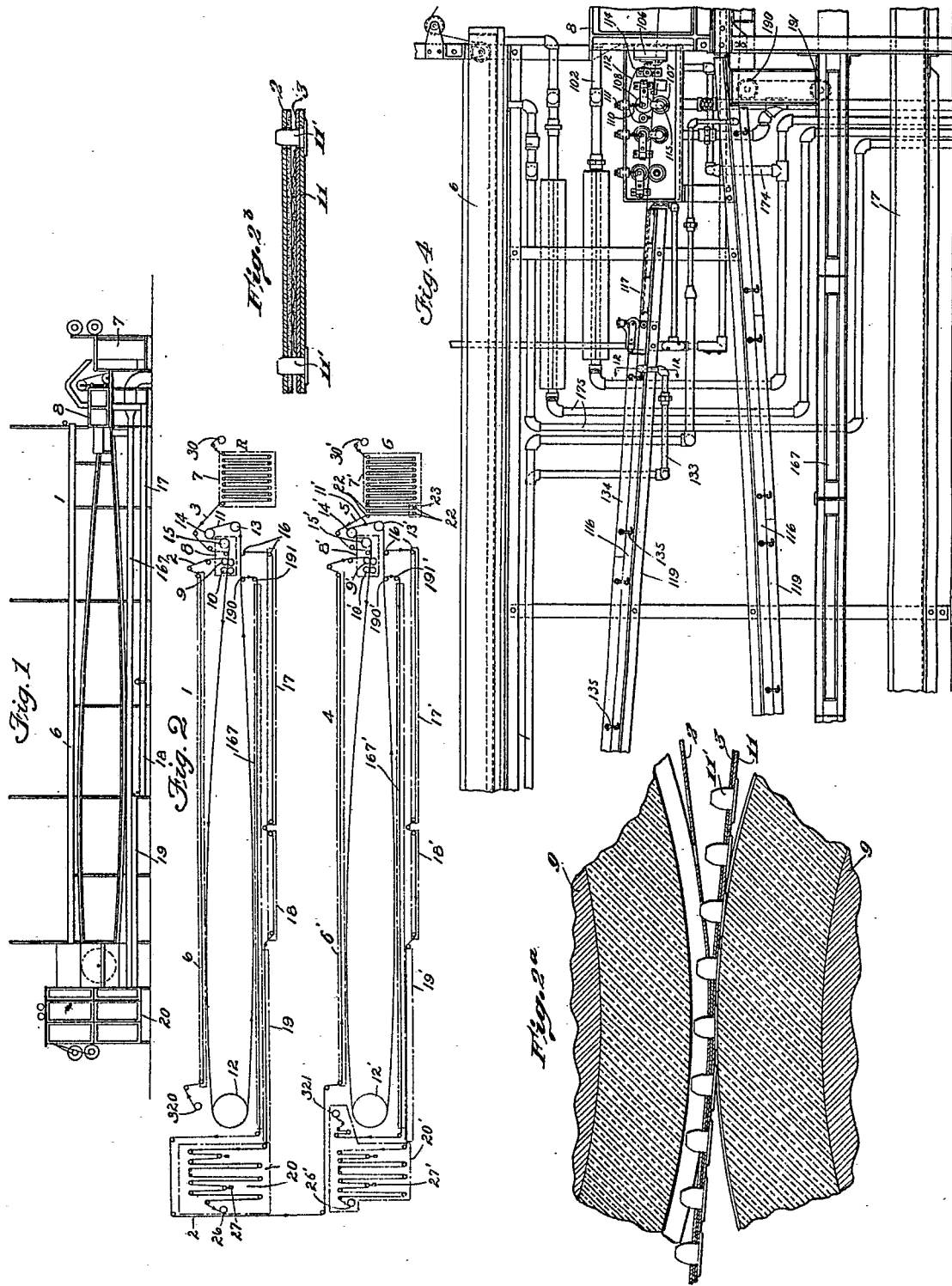

Fig. 4





[This Drawing is a reproduction of the Original on a reduced scale.]

[This Drawing is a reproduction of the Original on a reduced scale.]

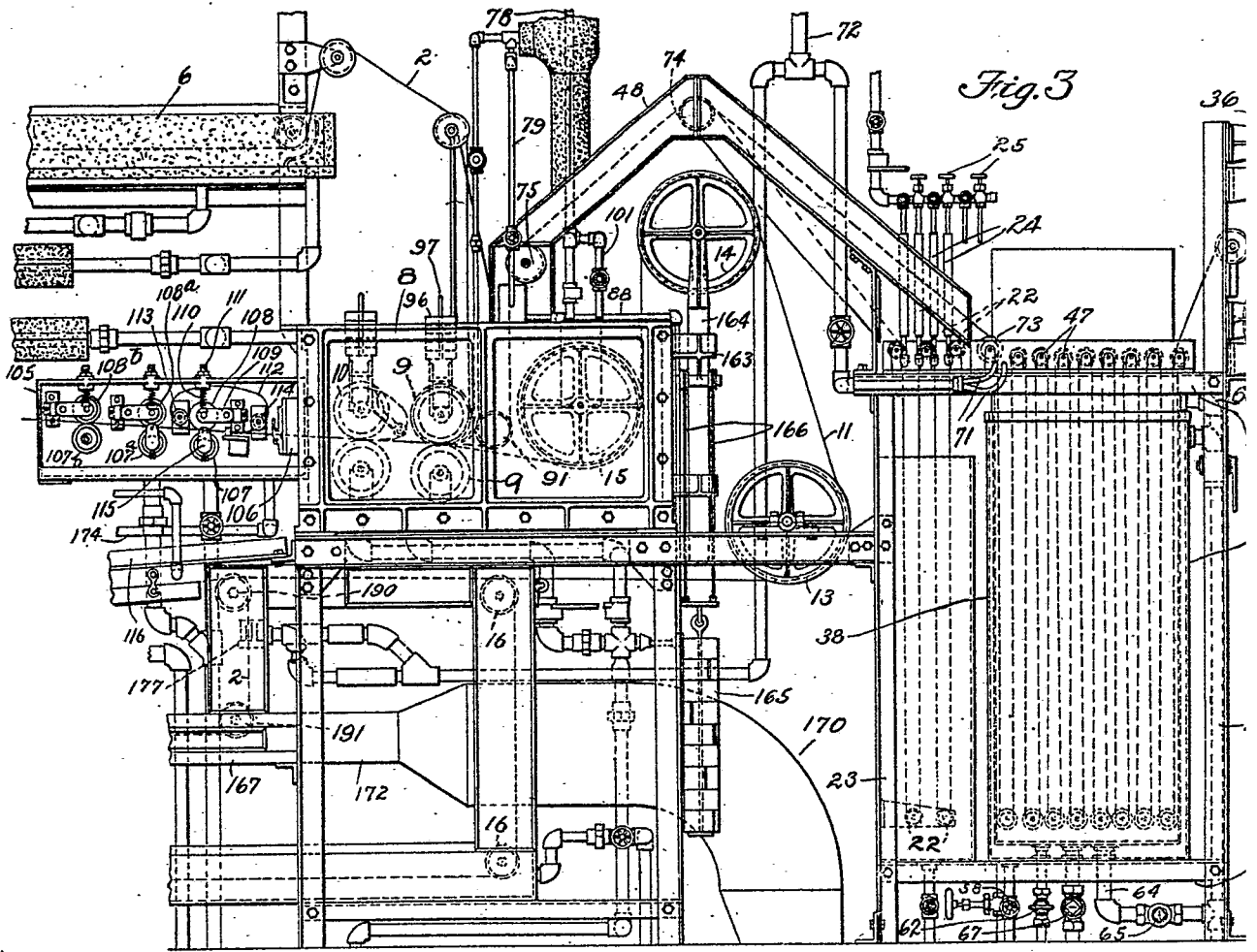

Fig. 3

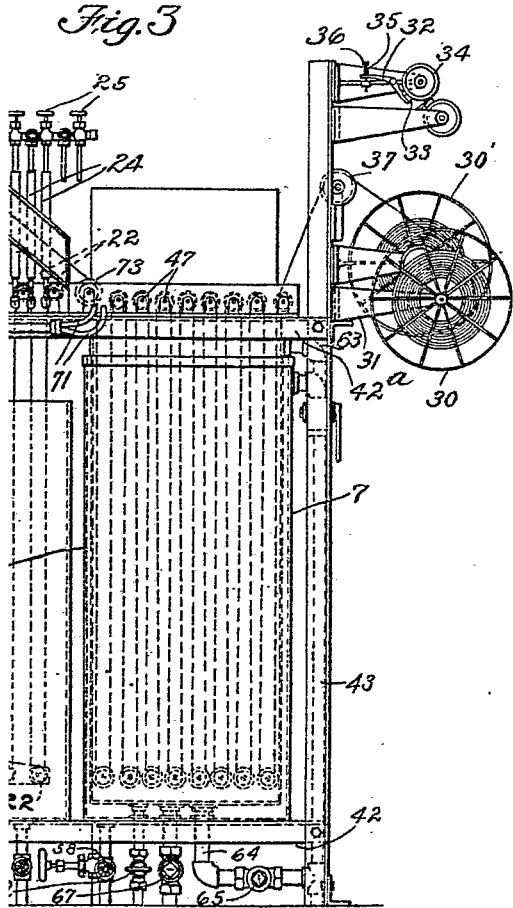

Fig. 6

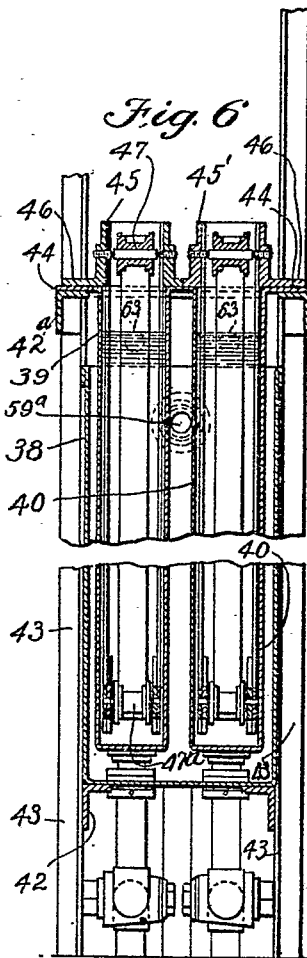
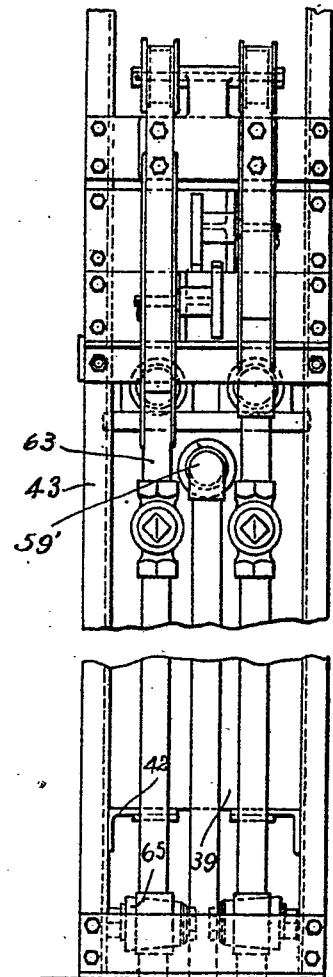
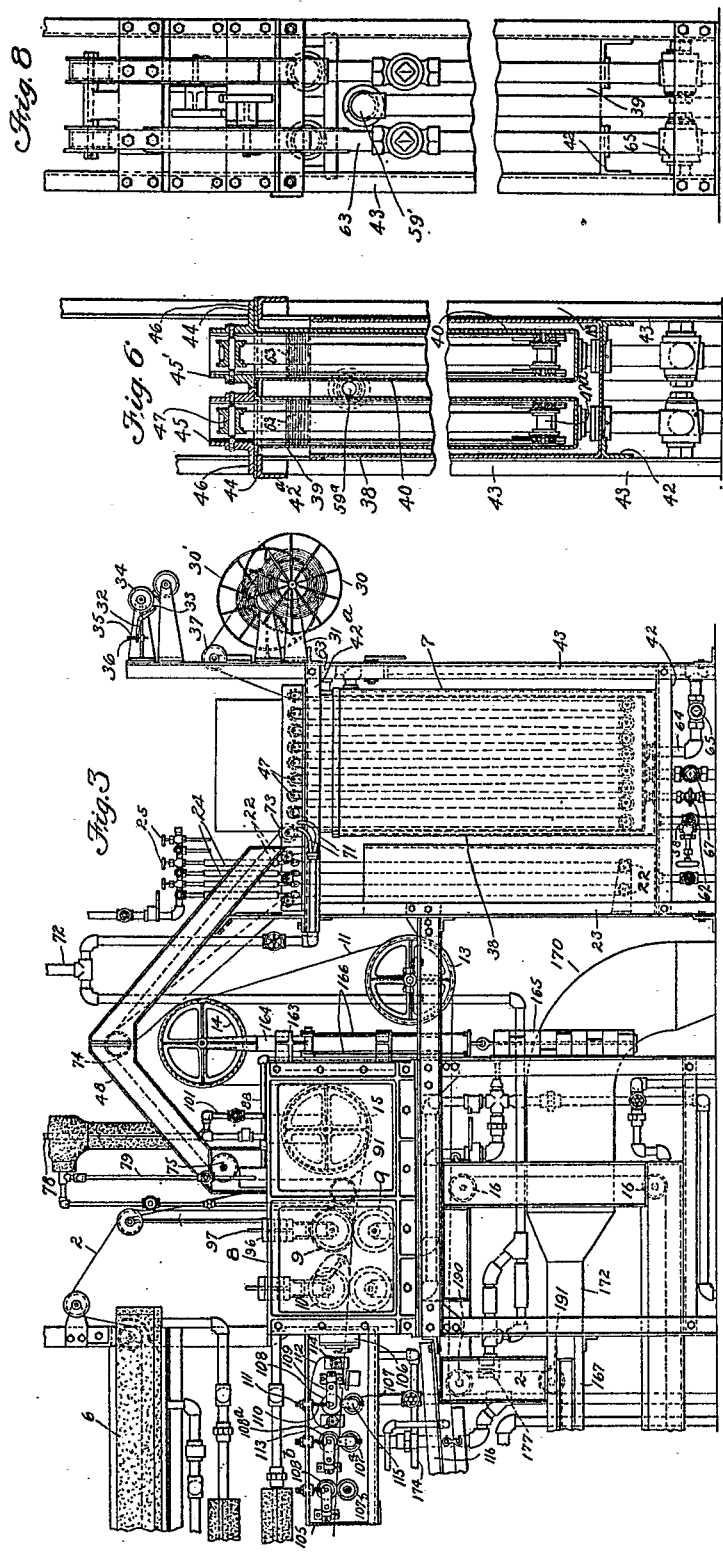

Fig. 8



[This Drawing is a reproduction of the Original on a reduced scale.]



[This Drawing is a reproduction of the Original on a reduced scale.]

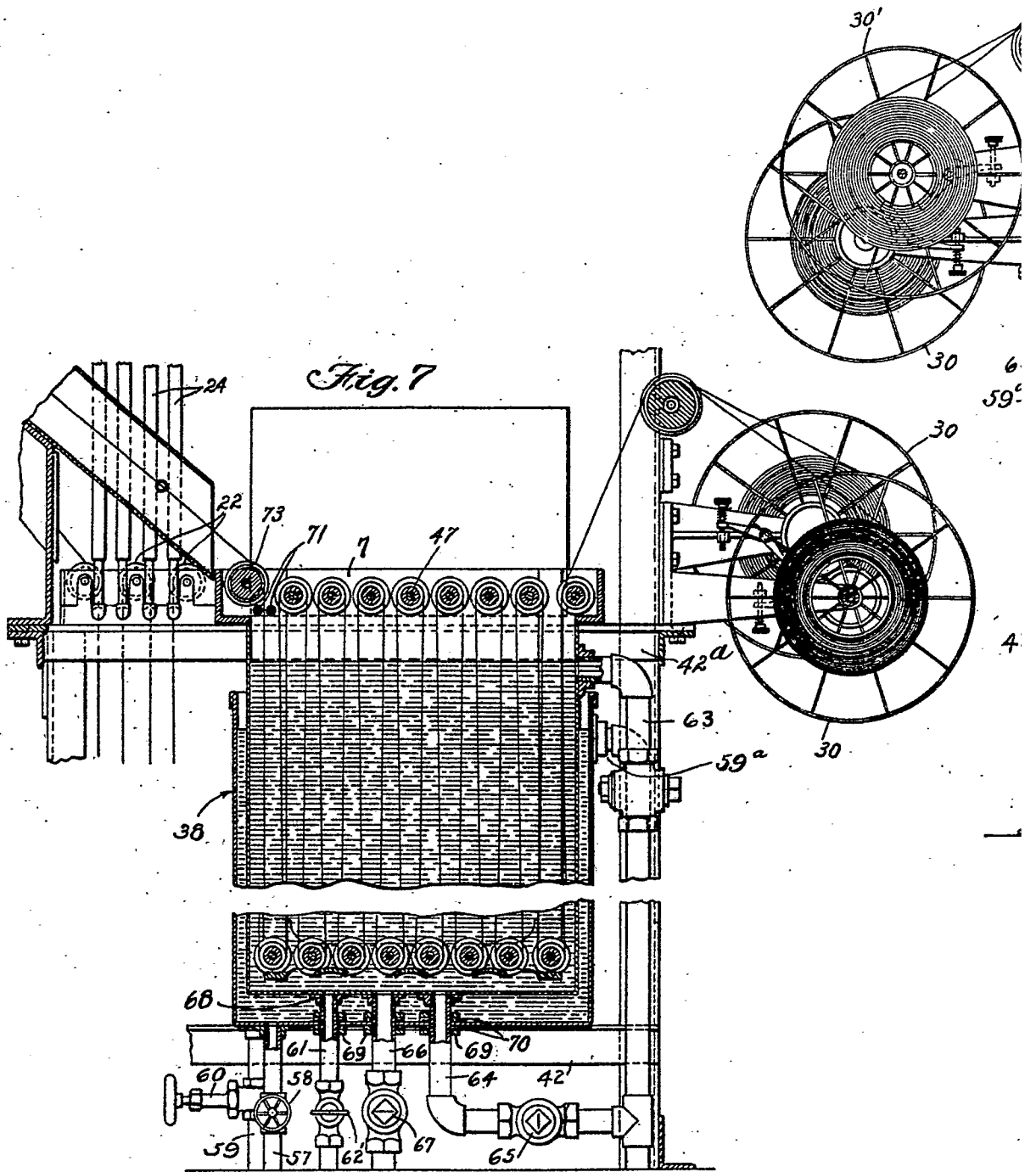

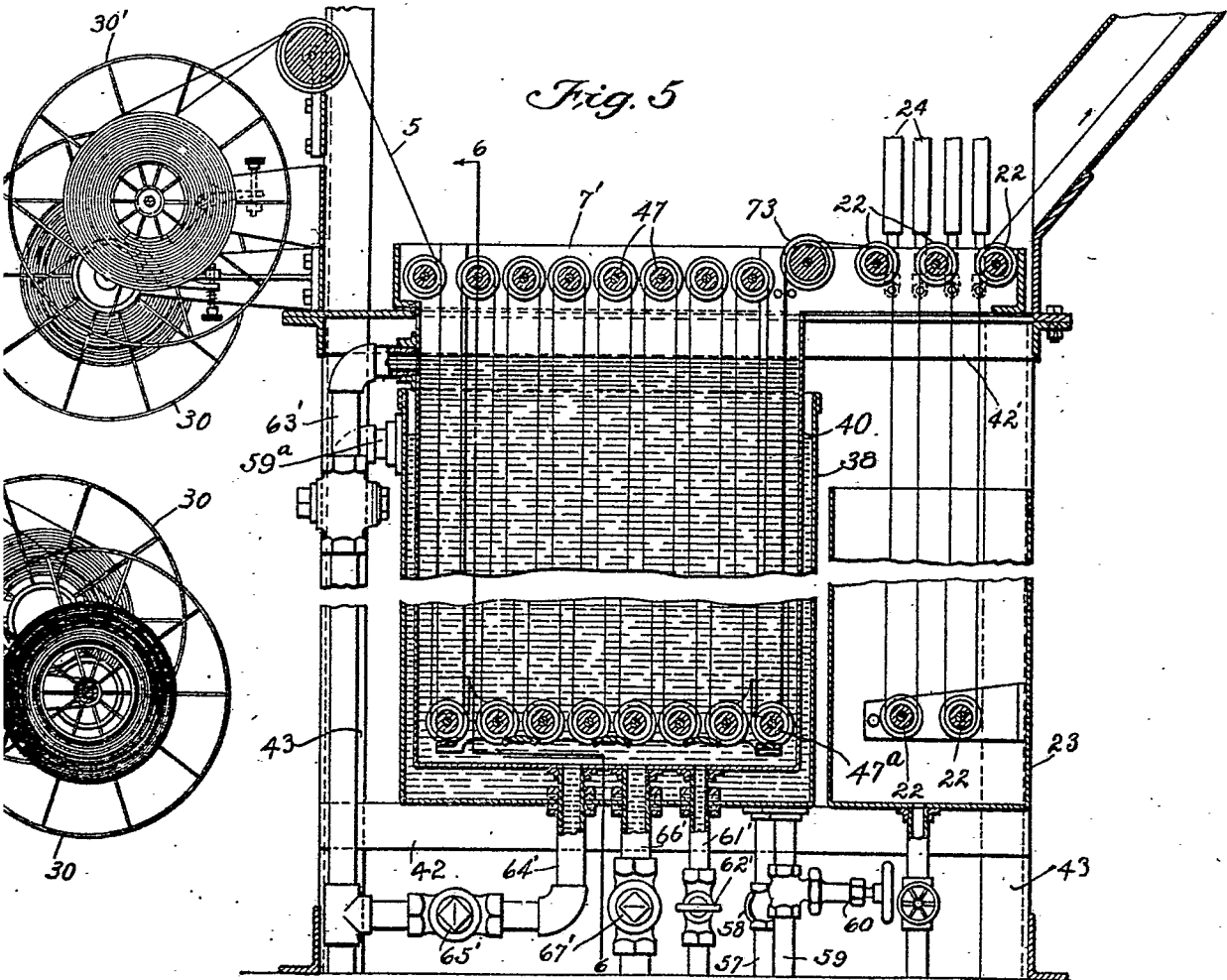

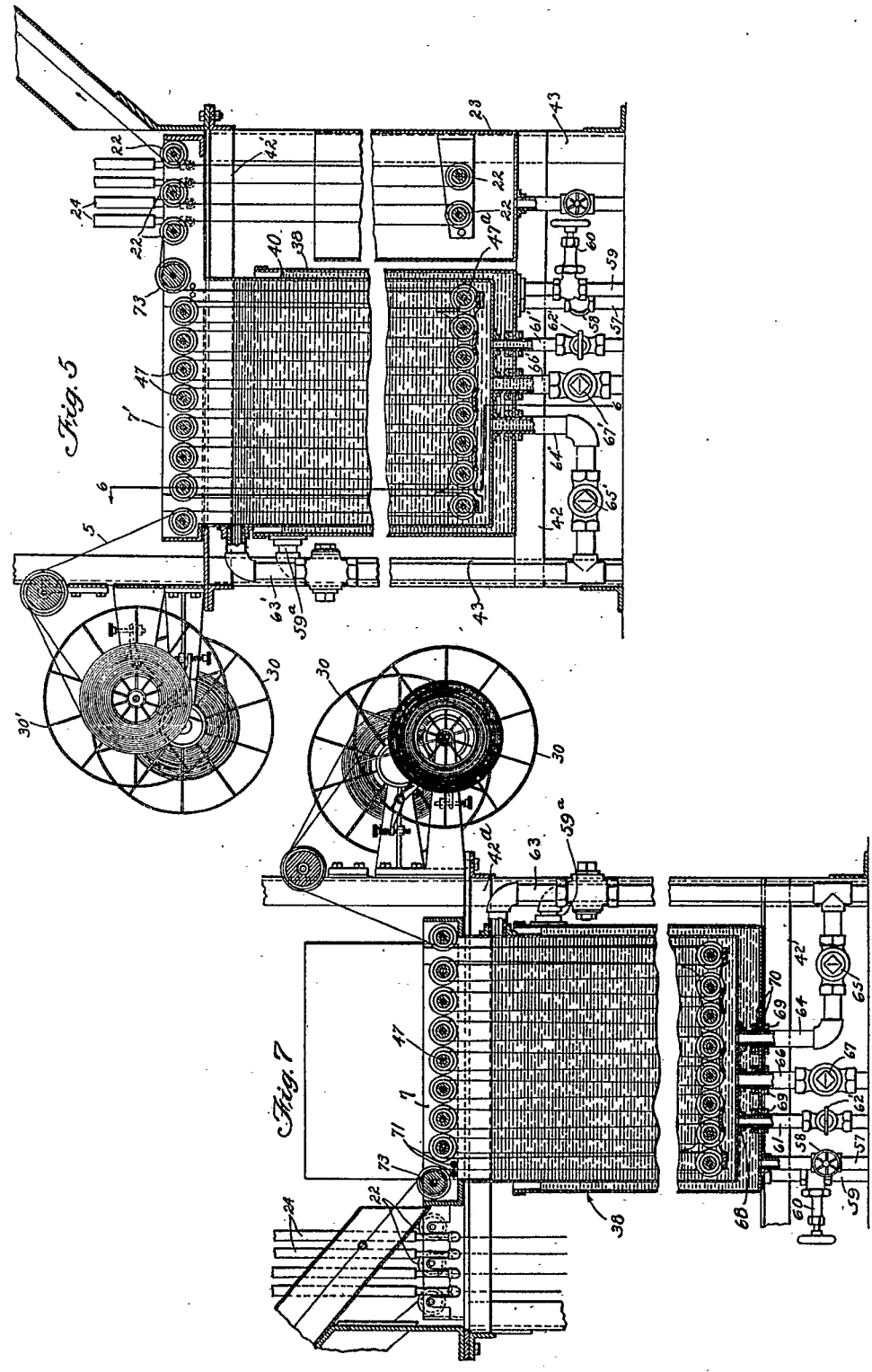

[This Drawing is a reproduction of the Original on a reduced scale.]

[This Drawing is a reproduction of the Original on a reduced scale.]

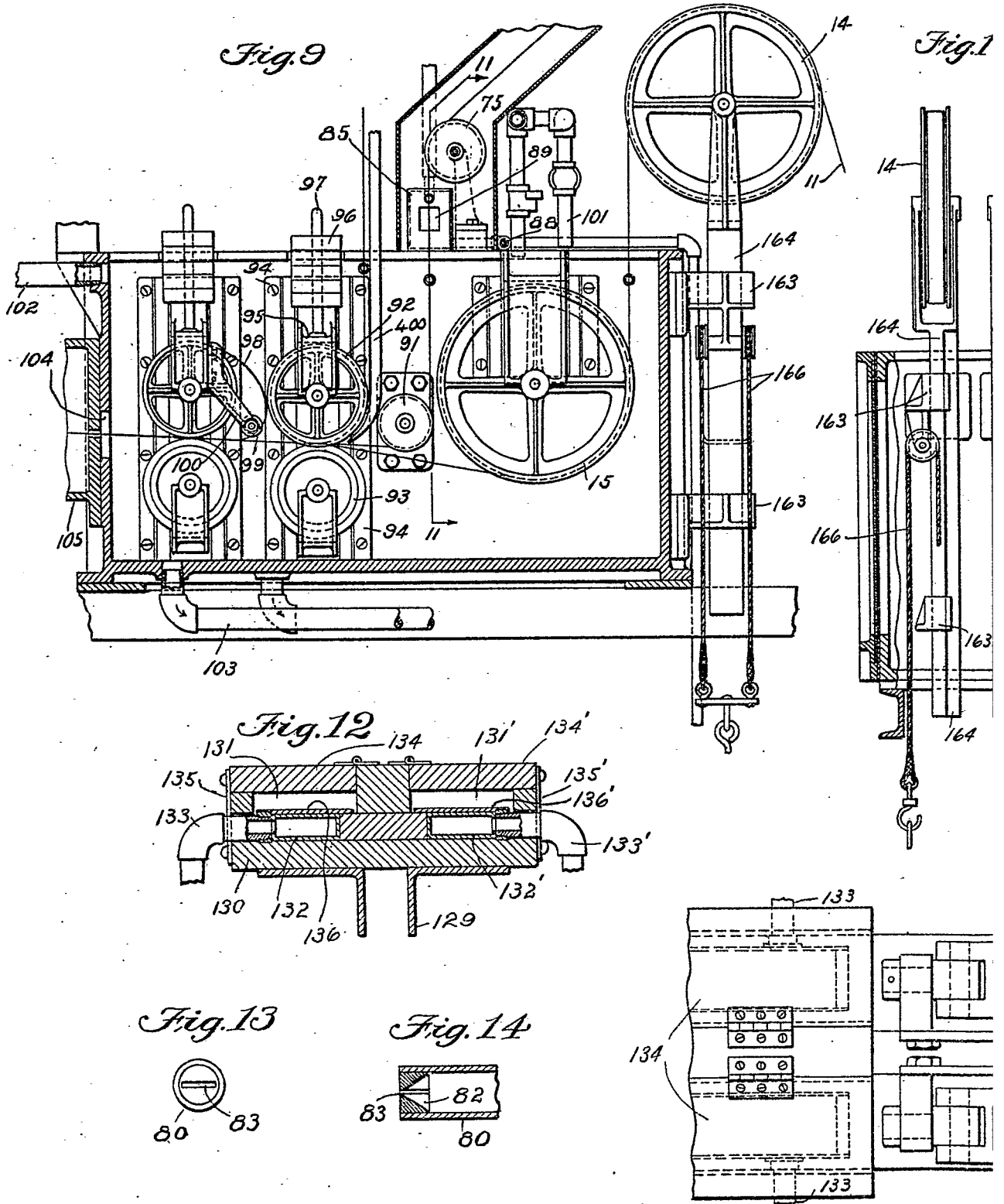

Fig. 11

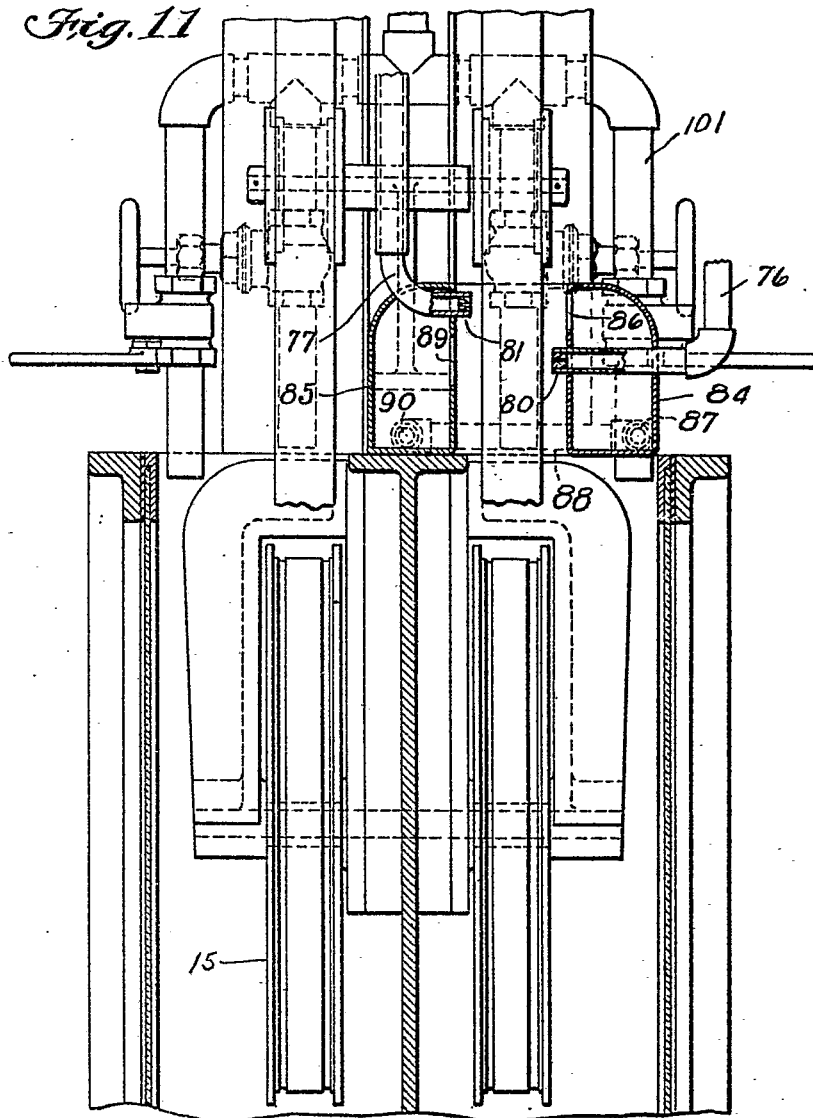

Fig. 10

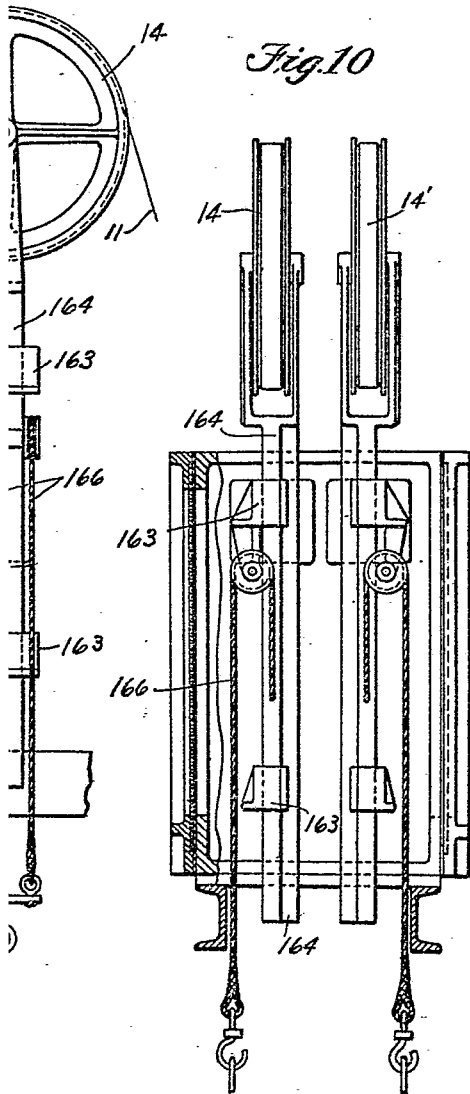
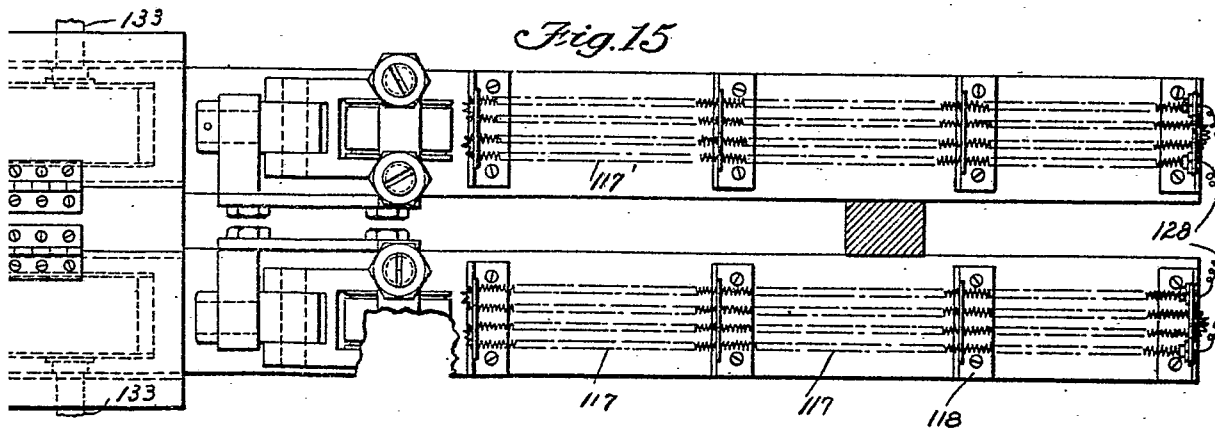

Fig. 15



[This Drawing is a reproduction of the Original on a reduced scale.]

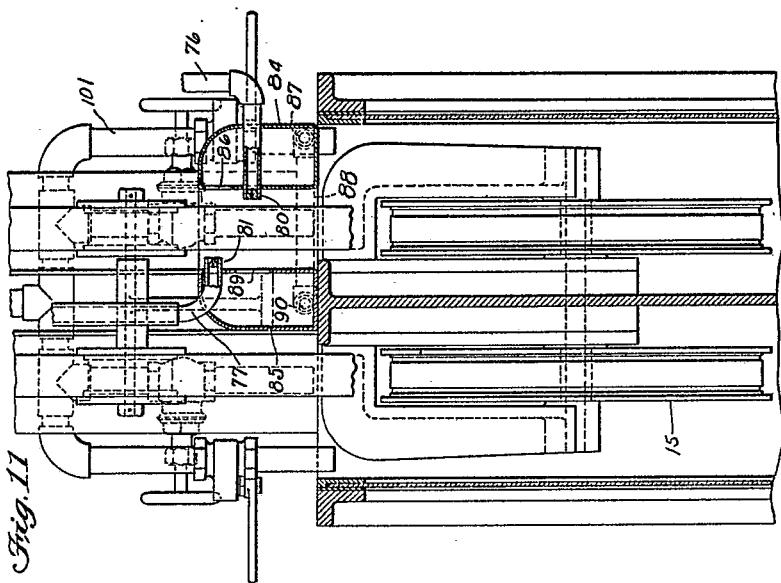

Fig. 11

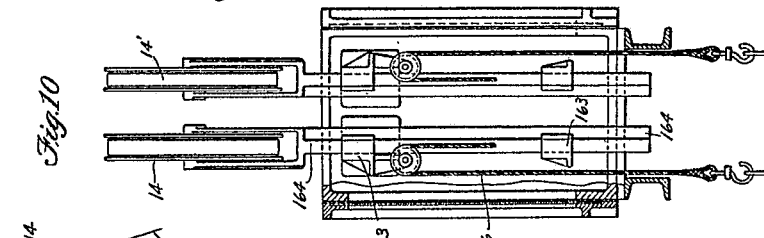

Fig. 10

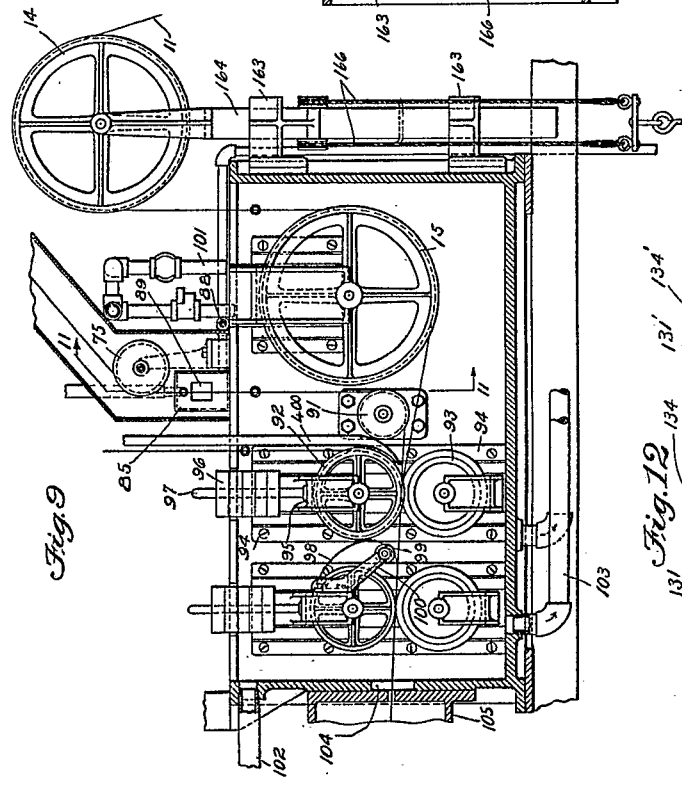

Fig. 9

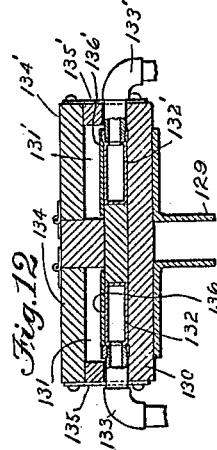

Fig. 12

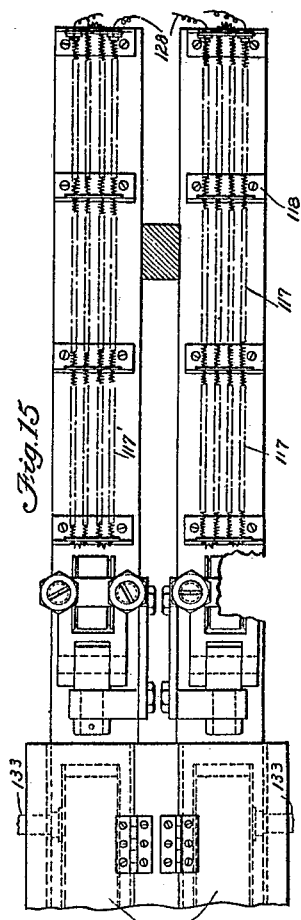

Fig. 15

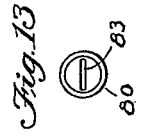

Fig. 13

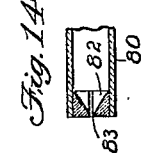

Fig. 14

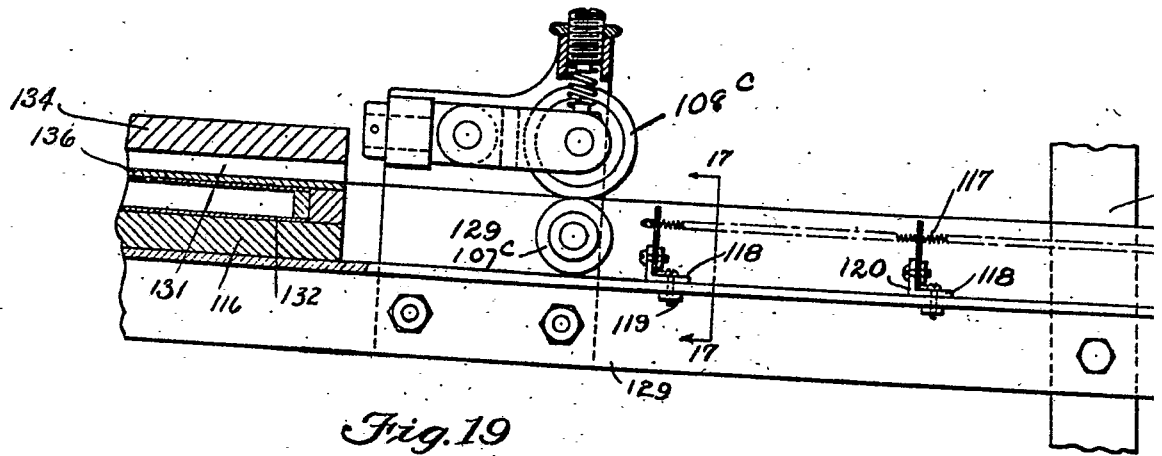

Fig. 19

Fig. 18

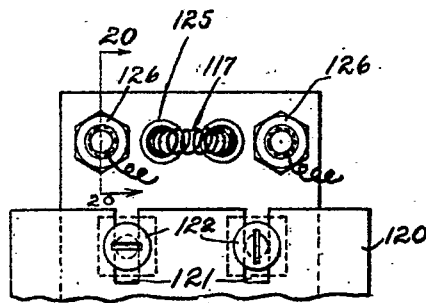
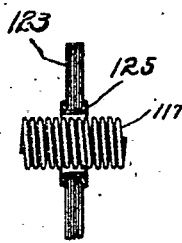

Fig. 20

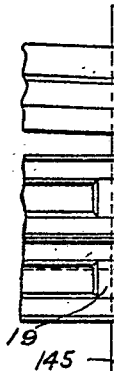
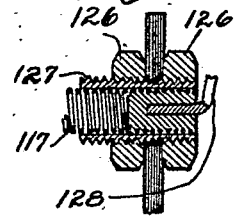

Fig. 23

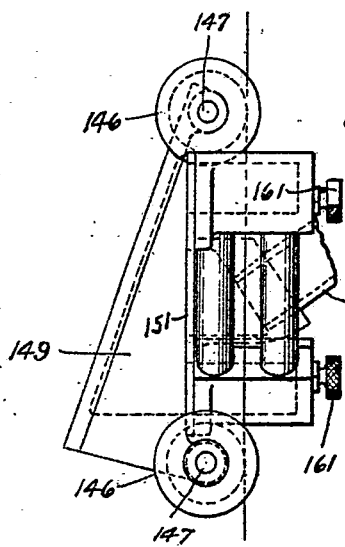
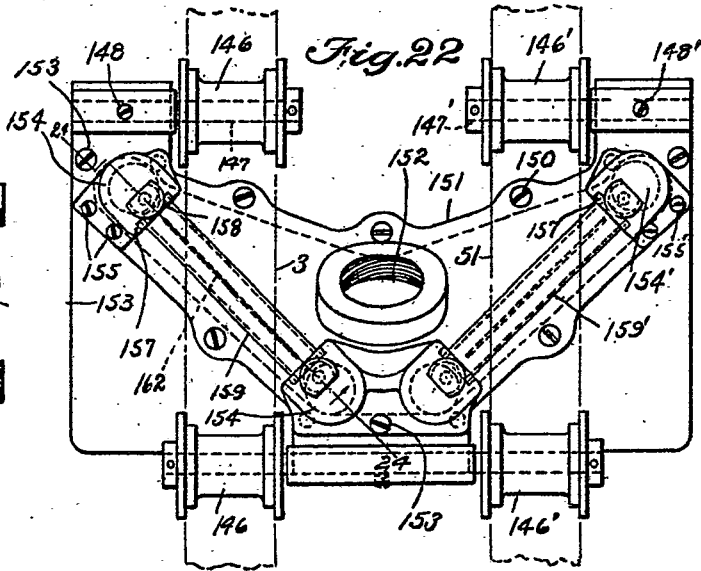
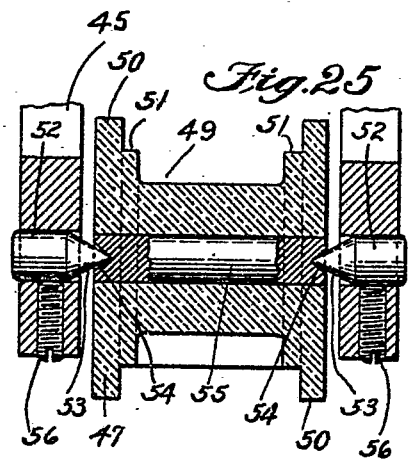
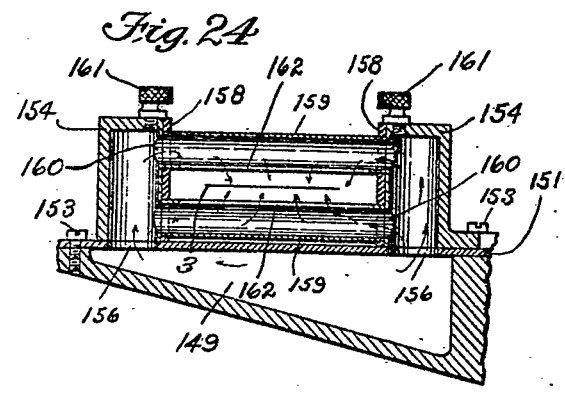
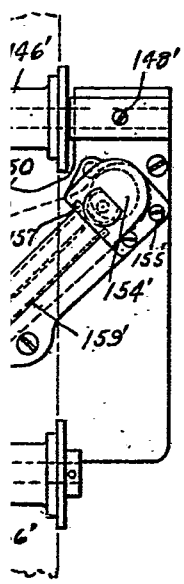
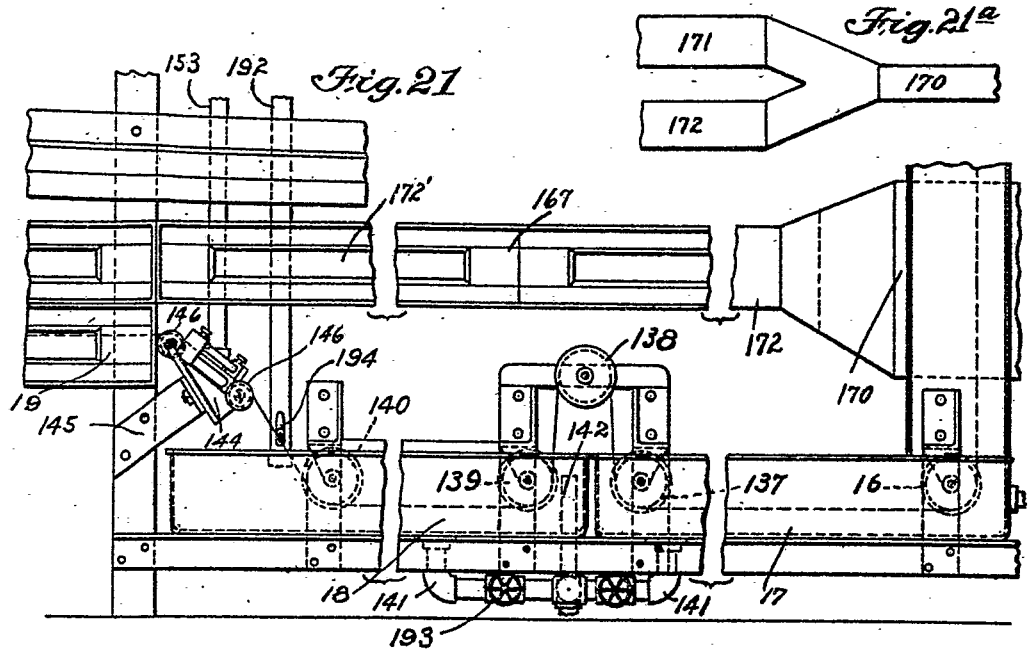
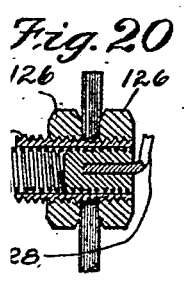
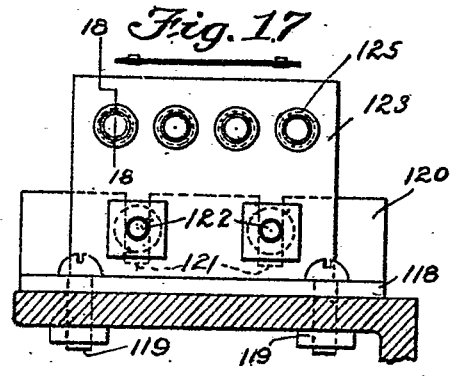
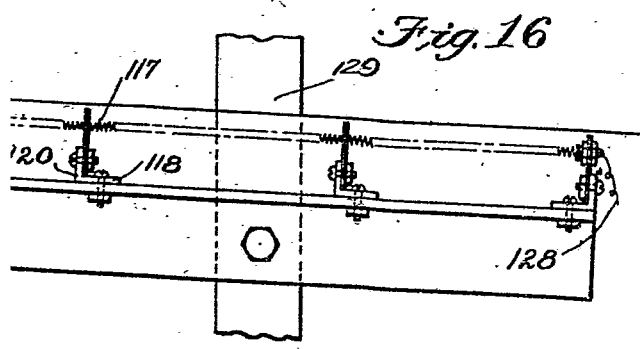

Fig. 22



[This Drawing is a reproduction of the Original on a reduced scale.]

154
161
1.



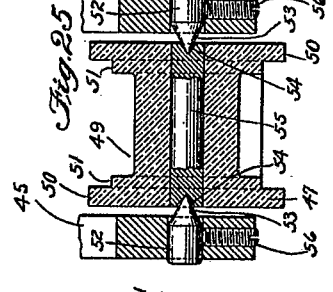
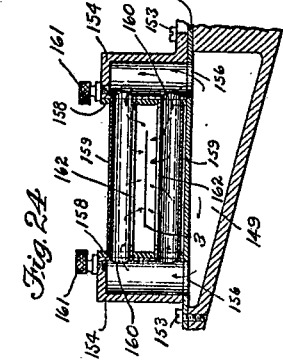
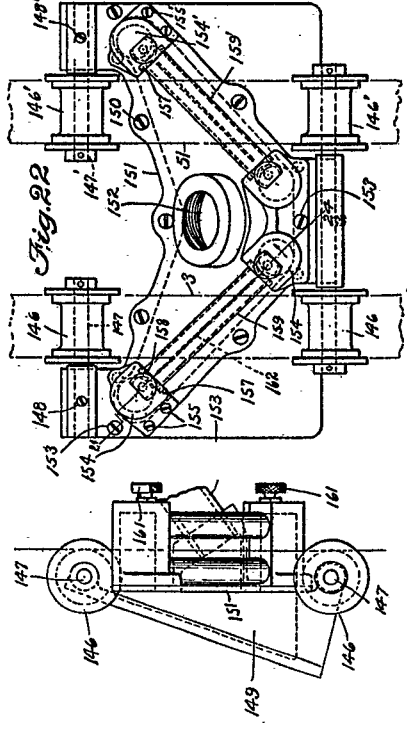
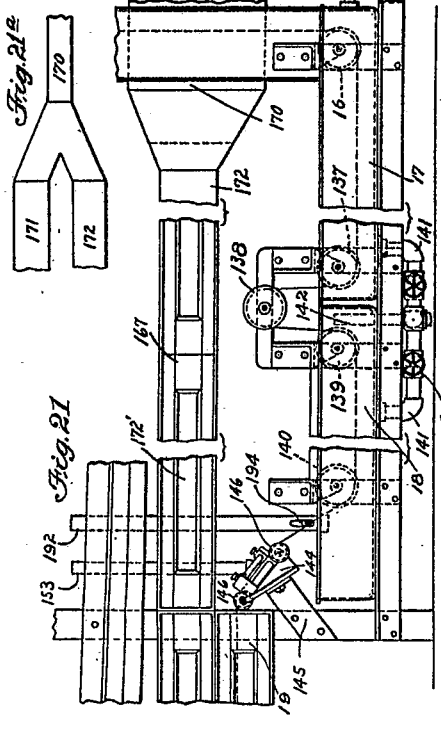
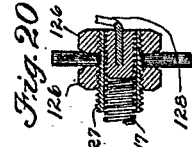
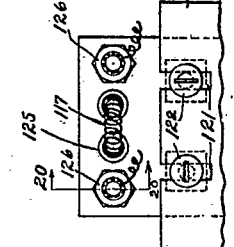
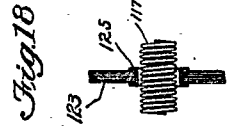
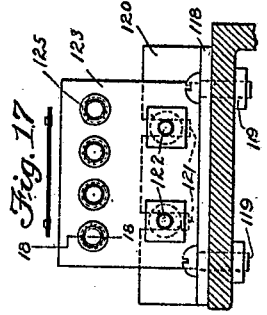
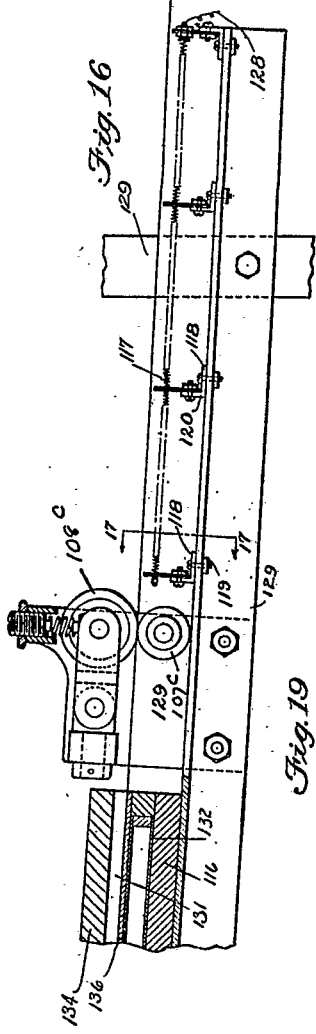

[This Drawing is a reproduction of the Original on a reduced scale.]