

Application Date: Dec. 21, 1927. No. 34,615 / 27.

Complete Accepted: Nov. 22, 1928.

COMPLETE SPECIFICATION.



Improvements in Cinematographic Apparatus.

We, TECHNOLOR MOTION PICTURE CORPORATION, a corporation of Maine, United States of America, and JOSEPH ARTHUR BALL, ERNEST AUGUSTUS GALLISON and EASTMAN ATKINS WEAVER, all citizens of the United States of America, all of 120, Brookline Avenue, Boston, Massachusetts, United States of America, do hereby declare the nature of this invention and in what manner the same is to be performed, to be particularly described and ascertained in and by the following statement:—

This invention relates to the continuous registration of a plurality of cinematographic films for any purpose, such as cementing two complemental films together with their images in exact superposition, but particularly for the purpose of printing a blank film from a matrix film by the imbibition of dye from one to the other film.

Owing to the shrinkage and expansion of films due to changing conditions of moisture to which they are subjected in the liquid processes of forming the images and in the air before and after the images are formed it is extremely difficult to bring the successive portions of long lengths of cinema films into registered superposition with the precision necessary for steady and uniform projection of the finished pictures. While this difficulty is encountered to some extent in the black-and-white branch of the art it is far more troublesome in the color branch of the art, particularly in subtractive films where the complemental images are disposed in superposition.

The object of this invention is to provide a method and apparatus by which cinematographic films of any length may be brought together in registry with speed and accuracy and without injury to the sprocket holes or other registering openings in the films.

According to the present invention the two or more films or other strips having sprocket holes or other registering perforations are fed along converging paths into superposed contact and the strips are conjointly subjected to retarding force in advance of the line of contact so that the

shorter strip is subjected to all the force until it is stretched to conform to the other strip, the retarding force being automatically regulated in proportion to the shrinkage of the shorter film and selectively applied to the strips respectively depending upon the relative degree of shrinkage throughout successive portions of the films. as by frictionally-retarded interconnected sprocket wheels engaging the perforations in the respective strips at locations in advance of the feeding means for automatically stretching the shorter strip to equal the longer progressively as the strips are brought into contact.

The invention will now be described with reference to the accompanying drawings in which:—

Figure 1 is a side elevational view of one form of apparatus;

Figure 2 is a similar view of a modified form of apparatus;

Figure 3 is an end elevational view partly in section of the registering drum shown in Figure 2;

Fig. 4 is a fragmentary side elevational view of another form of registering drum for use in the apparatus disclosed in Fig. 2;

Fig. 5 is an elevational view partly in section of the drum shown in Fig. 4;

Fig. 6 is a diagrammatical side elevation of another form of apparatus;

Figs. 7 and 8 are respectively a fragmentary side elevational and a radial sectional view of the registering apparatus for use in the modification shown in Fig. 6;

Figs. 9 and 10 are respectively a side elevational view and a radial sectional view of another form of registering apparatus for use in the modification shown in Fig. 6;

Fig. 11 is a side elevational view of another modification;

Fig. 12 is a transverse sectional view of the registering drum on the line 12—12 of Fig. 11; and

Fig. 13 is a plan view of a portion of the films as they appear at 13—13 of Fig. 11, showing the positions of the pins of drum 7*d* in the sprocket holes.

[Price 1/-]

The particular embodiment of the invention shown in Fig. 1 comprises a rotary drum 7 having film registering teeth or pins 18 on its periphery, the pins preferably being shaped to fit the film sprocket holes at their bases and being tapered toward their outer ends. The films are fed to and from the drum tangentially, approaching the drum at the bottom and leaving at the top as shown in Fig. 1. The two films 8 and 9 which are to be registered on the drum pass over sprocket wheels 10, thence over rollers 16 through guide 17, over the drum, through guide 23, over rollers 24, and thence over drive sprockets 25. The sprockets 10 are fast together with their teeth in alignment and are frictionally retarded by a brake comprising a disk 11 fast to the sprocket, and a non-rotating disk 12 pressed against disk 11 by a spring 14 bearing against a nut 15 on stationary shaft 13. The sprockets 25 are also fast together with their teeth in alignment and are adapted to be driven by gear 27 on shaft 26. Consequently, corresponding sprocket holes in the two films are positioned in transverse alignment at each set of sprockets and the intervening film is stretched into registration, the shorter film taking the tension until the films are equalized and the other film then sharing the residual tension if any. Thus the films are brought into potential registry before contacting with each other at point *a* and as they move upon the drum they may be more accurately registered by the tapered pins 18.

The pressure roll 19, mounted on an arm 20 swinging on shaft 21 and pressed against the drum by spring 22, presses the films into intimate contact as they advance upon the drum; and the films are then held in contact until they leave the drum at point *b* with the relatively light pressure resulting from the tension of the films between sprockets 10 and 25. The drum 7 is preferably rotated solely by the

In imbibition printing one of the films, e.g. the inner film 8 would be in the form of a relief or other matrix, while the other film might be a blank film provided with a dye absorbent gelatine coating. With the matrix dyed in any suitable way pictures are printed on the blank film in transit around the drum, the roller 19 pressing the films in intimate dye-transferring contact and the aforesaid tension retaining the films in close contact until the films leave the drum, the speed of the films being so adjusted that the dye transfer is completed before the films separate.

In cementing two complementary films together cement is applied to one or both

films before they contact and the cemented films pass off the drum to the same sprocket wheel, e.g. the lower wheel 25.

The embodiment shown in Figs. 2 and 3 is similar to that shown in Fig. 1 in that it comprises frictionally retarded sprockets 10¹, rollers 16¹, guide 17¹, pressure roll 19, drum 7*a*, registering teeth or pins 18¹, and drive sprockets, now numbered 33. Take-up rolls 31 and 32 are also shown in Fig. 2. However, this embodiment differs from that shown in Fig. 1 in that additional rolls 25¹ are provided and in that the teeth 18¹ are mounted in a different manner. The rolls 25¹ may be employed positively to hold the sprocket holes of the two films in transverse alignment intermediate the sprockets 10¹ and 33, and one of the rolls 16¹, e.g. the upper roll, may be in the form of a dye roll or cement roll for applying dye or cement to one of the films.

The pins 18¹ are mounted on spokes 28 which are mounted in the hubs 30. The spokes 28 are movable circumferentially, as for example, by flattening the portions 29 so that they may flex circumferentially, the flexible portions having sufficient elasticity normally to hold them in radial position and to urge them into radial position when flexed to one side of this position. The spokes 28 extend outwardly through slots in the periphery of the drum, whereby the pins 18¹ may move circumferentially of the drum to accommodate themselves to the sprocket holes in the films. In this way the films are not forced to conform to a predetermined spacing of the pins but are merely forced to conform to each other, the pins merely interlocking the films together. This arrangement accommodates variations in the spacing of the sprocket holes due either to unequal shrinkage or to different degrees of stretching.

In Figs. 4 and 5 is disclosed a modified form of registering drum 7*b* which may be substituted for drum 7*a* in Fig. 2. The periphery of the drum has radially extending marginal flanges 35 forming a guideway for the films and a hub 36 slotted at 37 to receive the base portions of flat spring spokes 38 (Fig. 5). These spokes may have flanged portions 39 extending perpendicularly to one surface thereof to be made fast to the web 40 of the drum 7*b* in any suitable manner as by screws 41. The free ends of aligned pairs of spokes 38 are tied together by cross pieces 42 having film engaging pins 43 extending through peripheral slots 44 in the guideway of the drum. The cross pieces 42 extend through slots in the web 40 of the drum (Fig. 4) and may be fastened to the spring spokes 38 by bolts

45. The spring spokes of the modification shown in Figs. 4 and 5 operate in the same manner as spokes 28 in Figs. 2 and 3 to effect stretching and exact registration of the films.

The modified form of apparatus disclosed in Fig. 6 provides means for positively moving the registering pins against a yielding force to stretch the films prior to the application of pressure. Films 8 and 9 pass from magazine drums 46 and 47 over retarding sprockets 48 and 49 and thence together partly around registering drum 7c where heavy pressure is applied thereto by pressure roller 50. While still in contact the films leave registering drum 7c and pass around spokeless drum 51, the films still in contact passing from drum 51 around drive sprocket 52, the films being maintained in contact with the sprocket by a guide roller 53. Then the films are separated and wound upon frictionally driven take-up drums 54 and 55.

Adjacent registering drum 7c is a cam plate 56 fast to the frame (not shown) in which the apparatus is supported. The cam plate 56 has a cam groove 57 comprising a lower run extending from point *a* to point *b* whence the groove rises at *c* to the intermediate level, which extends to point *d*, thence to a high run *e* of short duration which gradually merges into the low run at point *a*.

The registering drum 7c is disclosed in detail in one form in Figs. 7 and 8 and in another form in Figs. 9 and 10. In the form shown in Figs. 7 and 8 the registering pins 58 are supported on cross bars 59 extending through a slot in the web of the drum 7c, each bar being integral with or otherwise fast to an arm 60 substantially parallel to the web of the drum and mounted for swinging movement thereon by means of a pivot 61. There is likewise supported upon pivot 61 a sliding tension frame 62 having slots 63 through which pivot 61 extends, the free end of the frame terminating adjacent the upturned end 64 of arm 60, the latter supporting a tension rod 65 extending within the frame 62. Between head 66 of rod 65 and the lower end of frame 62 is a spring 67 adapted to be adjustably tensioned by an adjusting nut 68 on the end of rod 65. Frame 62 has oppositely disposed ears 69 and 70 extending therefrom which normally contact with pins 71 on an arm 72 pivoted on pivot 61. Arm 72 has a post 73 extending therefrom upon which is a roller 74 which extends into the cam groove 57 in cam plate 56.

Referring now to Fig. 6 for a description of the operation of registering pins 58 for stretching the films into registration, roller 74 takes the extreme rise in

the cam groove 57 at *e* or just as the films 8 and 9 reach the vicinity of the drum 7c; hence the arm 72 is rocked upwardly, one of the pins 71 acting upon ear 70 to swing frame 62 and arm 60 to the right (Fig. 7), so that the registering pins are swung to the left to facilitate the entrance thereof into the sprocket openings of the films. Immediately thereafter the roller 74 follows the downward slope of the cam groove 57 to the point *a*. This swings arm 72 downwardly so that the other pin 71 operates upon ear 69 of frame 62 to swing the frame and arm 60 to the left, thus moving pins 58 to the right to stretch the films against the pull of the retarding sprockets 48 and 49. If the tension of the films exceeds the tension of spring 67 the arm 60 may remain stationary while the frame 62 moves upwardly against the tension of spring 67 to the limit of slots 63 so that the lifting effect of pin 71 upon ear 69 will not serve to swing arm 60 and thus damage the film. Hence it will be apparent that this arrangement provides a positive means for moving the registering pins 58 to stretch the films into registration but that this stretching effect is limited by the tension placed upon the spring 67 which will yield and permit frame 62 to move upwardly and the arm 60 to remain relatively stationary if the pull upon the films is such as to be likely to damage the latter.

The modified form of drum 7a disclosed in Figs. 9 and 10 is similar to the form shown in Figs. 7 and 8, the difference consisting in the substitution of a tension arm 75 in place of the tension frame 62 which produces a somewhat lighter structure. The device is otherwise essentially the same and operates in the same manner.

In the modification shown in Figs. 11 and 12 the exact registration of the films takes place entirely upon the registering drum 7d. The path of films 8 and 9 in this instance is from suitable reels not shown to registering drum 7d at the point *h*, thence half way around the drum to the point *i* where the spring-pressed roller 77 forces the two films together. At the point *j* the films still pressed together are transferred to a spokeless drum 78 where the films are held together for a predetermined time and thence to the take-up reels 79 and 80 which may be frictionally driven to pull the films through the apparatus.

The registering frame 7d is mounted for rotation on a shaft 81 supported in suitable bearings in stationary side plates 82. The hub 83 of the registering drum has attached thereto a flanged plate 84 in the flanges 85 of which are pivoted spokes

86. These spokes extend through guide openings or slots 87 in annular flanges 88 mounted in spaced relation upon a plate 89 from which extends the circular disc 5 or web 90 which supports the peripheral surface 91 upon which the films 8 and 9 are disposed. Spokes 86 are provided adjacent their free ends with weights 92. Disposed intermediate weighted spokes 86 10 and extending from slotted flanges 88 are spring spokes 93 which as illustrated are similar in all respects to spring spokes 28 shown and described in the modification of the apparatus disclosed in Figs. 2 and 15 3. The free ends of spring spokes 93 are provided with pins 94 and 95, pin 94 completely filling the sprocket opening in the film both lengthwise and crosswise as clearly indicated in Fig. 13 and pin 95 20 closely fitting the sprocket openings longitudinally but not transversely. The pins 96 upon the weighted spokes do not closely fit the sprocket openings in the film in either direction as shown in Fig. 13 for a 25 purpose presently to be described.

Extending adjacent registering drum 7*d* for substantially one-quarter of its circumference are spacing tongues 97 fastened upon side plates 82 in which the drum is 30 supported. These spacing tongues as shown in Fig. 12 extend inwardly between the marginal portions of the films 8 and 9 and prevent the two films from coming into direct contact during the period of 35 relative adjustment between the films for effecting exact registration.

The operation of the apparatus disclosed in Fig. 11 is as follows. Films 8 and 9 40 approach registering drum 7*d* tangentially at the base thereof as indicated in Fig. 11, matrix film 8 extending between spacing tongues 97 and supporting surface 91 of the drum and blank film 9 being disposed 45 outwardly of spacing tongues 97, although the pins 94, 95 and 96 on spokes 86 and 93 extend through the sprocket openings of both films. As drum 7*d* turns in the direction of the arrow the weights 92 upon spokes 86 tend to draw down upon 50 the film against spring spokes 93. This drawing force or pulling upon the superposed films, which are retained out of contact by spacing tongues 97, reaches its maximum when the spokes are horizontally 55 disposed and adjacent the point where spacing tongues 97 terminate, namely at point *k*. By the time point *k* is reached the pulling effect produced by the weighted spokes will have brought the 60 films into exact superposition. This drawing effect is most pronounced upon the inner or matrix film 8 which is supported by surface 91 of the drum, hence a much greater pulling force can be used upon the 65 film than is possible with apparatus of the

type shown in Figs. 1 and 2 where the film is not supported. Tests have demonstrated that force to the extent of two pounds per square inch may be applied to a film so supported without tearing the 70 sprocket holes as compared with one-fifth of that force when the film is not supported on a smooth surface.

The manner in which the spring and weighted spokes act upon the superposed 75 films is clearly illustrated by the plan view of Fig. 13 where the pins 94 and 95 of the spring spokes bring the two films into accurate transverse alignment and pins 96 of the weighted spokes through 80 their stretching effect produce accurate registration longitudinally. The pressure for forcing the two films into contact to begin the imbibition process is applied at the top of the drum 7*d* where the pulling 85 effect of the weights on spokes 86 is neutralized. The two films are thence held together by light pressure imposed by the drawing effect exerted upon the film by the take-up reels 79 and 80 during the 90 period in which the two films remain together, namely, on registration roller 7*d* from the point *i* to the point *j* and on the imbibition drum 78 from the point *j* until 95 the films pass therefrom to their separate take-up reels. As the films pass beyond the point *i* at which pressure is applied, the weighted spokes 86 produce a pulling effect upon the films in the opposite direc- 100 tion to that previously applied and prevent creeping or relative movement of the films upon one another under the heavy pressure of roller 77.

Experiments have demonstrated that the transferring of images by imbibition 105 is best effected by a heavy pressure applied momentarily followed by a light pressure extending over a period of 20 or 30 seconds and that thereafter the process continues 110 whether or not pressure is applied thereto. In the apparatus disclosed in Fig. 11, provision is made for all of the steps in the process as outlined above, a heavy 115 pressure being applied at the point *i*, the lighter pressure being maintained from the point *i* to the point *j*. After passing point *j*, pressure upon the two films is not essential but light pressure is still applied 120 thereto due to the drag on the films produced by the frictionally driven take-up reels 79 and 80. The process is similarly completely performed by the apparatus 125 disclosed in Fig. 6. If desired, an imbibition drum such as 51 (Fig. 6) or 78 (Fig. 11) may be used with the apparatus shown in Fig. 1 or Fig. 2.

If desired, a preliminary stretching of the films may be effected before the latter 130 pass upon registering drum 7*d* (Fig. 11).

One form of apparatus for this purpose may comprise sprockets 98 and 99, each engaging the sprocket openings in one of the films. These sprockets may be geared together to turn at the same rate and one may be provided with a brake drum 100 having an adjustable brake band 101 frictionally engaging the same whereby the rotation of both sprockets is equally retarded for the purpose of stretching the films.

From the above it will be apparent that the forms of apparatus disclosed provide for the continuous printing of strip films by imbibition, that the films are accurately registered both longitudinally and laterally before they are permitted to come into intimate contact, that by the provision of a pulling force against yielding or retarding mechanism the shorter of the two films is selectively and automatically stretched to conform to the longer film without danger of injury to either, that the heavy pressure necessary to force the films into contact to begin the imbibition process is applied immediately after the films are brought into exact registration and while they are so held, that the films are restrained against relative movement during the application of pressure, and that the films are maintained in contact under light pressure thereafter until the transfer of images is completed.

By spacing the film-advancing means (sprockets 25 in Fig. 1) and the film retarding means (sprockets 10) of the respective films equal distances apart along the paths of the films respectively and arranging the retarding sprockets to operate conjointly so that the shorter film is subjected to all the retarding force until it is stretched to conform to the other film and then both films are subjected to the residual stretching force, the films are automatically registered intermediate the sprockets irrespective of variations in the inequalities of the films throughout their lengths; that is, the retarding forces are automatically proportioned, between the respective films in accordance with the difference in length of the films so that the films are always registered. If the difference in length of the two films increases a greater proportion of the retarding force is applied to the shorter film and less residual force remains to be counteracted by the longer film; if the difference in length decreases more of the force is applied to the longer film; if corresponding portions of the films are equal in length the films are stretched equally; and if throughout subsequent portions the inequality is reversed then the greater proportion of the retarding force is automatically shifted to the other film,

Having now particularly described and ascertained the nature of our said invention and in what manner the same is to be performed, we declare that what we claim is:—

1. In the art of cinematography, using strips having registering means in the form of series of perforations therein, the method of superposing the strips with the perforations in precise registry, which comprises feeding the strips along converging paths into superposed contact, and applying a retarding force to both strips conjointly in advance of the line of contact, so that the shorter strip is subjected to all the force until it is stretched to conform to the other film and then both films are subjected to the force.

2. The method of bringing two cinematographic strips into registered contact for imbibition printing from a matrix film to a blank film or for cementing the two films together or the like, one of which may be shorter than the other due to shrinkage or the like, which comprises feeding the two films into superposed contact and concomitantly applying a retarding force to the shorter film to stretch it throughout a predetermined portion in advance of the line of contact between the films, characterized in that the retarding force is automatically regulated in proportion to the shrinkage of the shorter film, to stretch the shorter film to a predetermined standard length, whereby the two films are brought together with their sprocket holes in accurate register.

3. Method according to Claim 2 further characterized in that the retarding force is automatically and selectively applied to the films respectively depending upon the relative degree of shrinkage throughout successive portions of the films.

4. Apparatus for practising the method of the preceding claims having means engaging said perforations for the aforesaid strip feeding, characterized by means engaging the perforations in the respective strips at locations in advance of the feeding means for automatically stretching the shorter strip to equal the longer strip.

5. Apparatus according to the preceding claims further characterized in that the stretching means engaging the respective strips are mechanically interconnected to move in synchronism.

6. Apparatus according to the preceding claim further characterized in that said means comprises sprocket wheels frictionally retarded.

7. Apparatus according to any of the preceding claims further characterized by registering pins extending radially from a film drum and supported for peripheral

movement to accommodate the dimensions
between the holes of the stretched films.

Dated the 21st day of December, 1927.

WM. BROOKES & SON,
London & Lancashire House,
5, Chancery Lane, London, W.C. 2,
Chartered Patent Agents.

Redhill: Printed for His Majesty's Stationery Office, by Love & Malcomson, Ltd —1928.

[This Drawing is a reproduction of the Original on a reduced scale.]

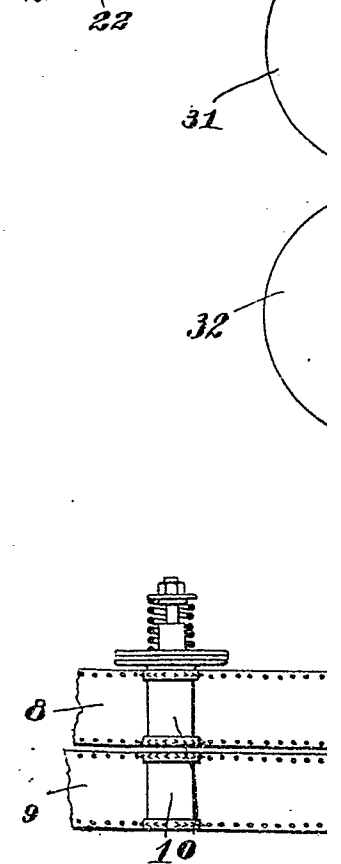
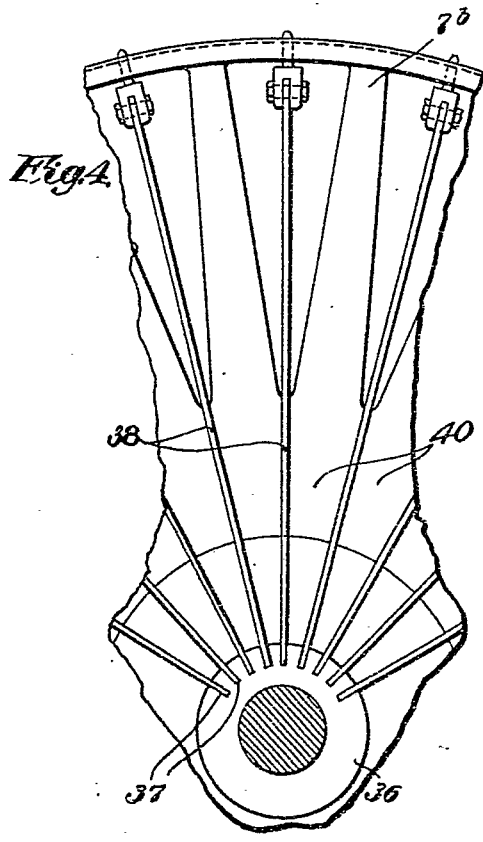
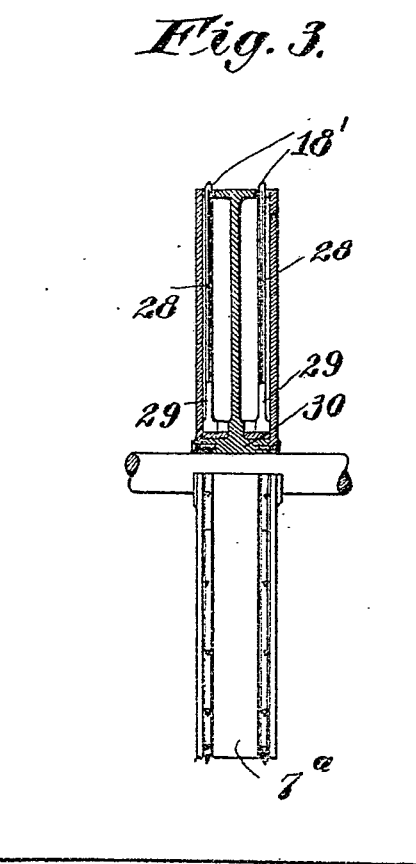
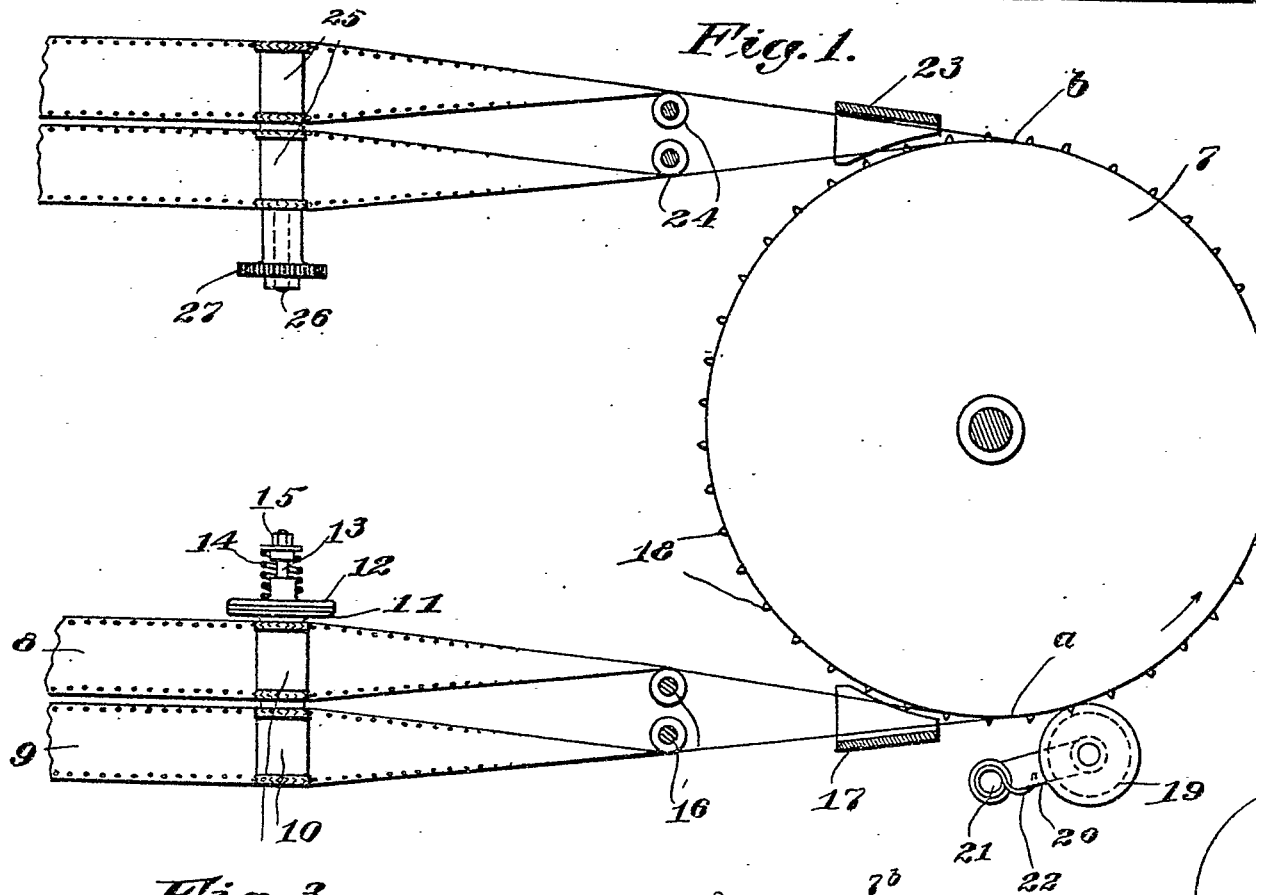

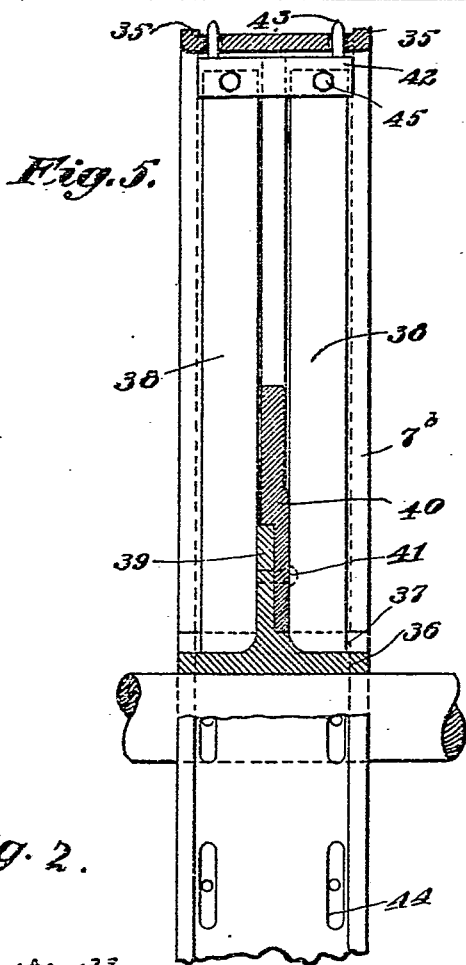
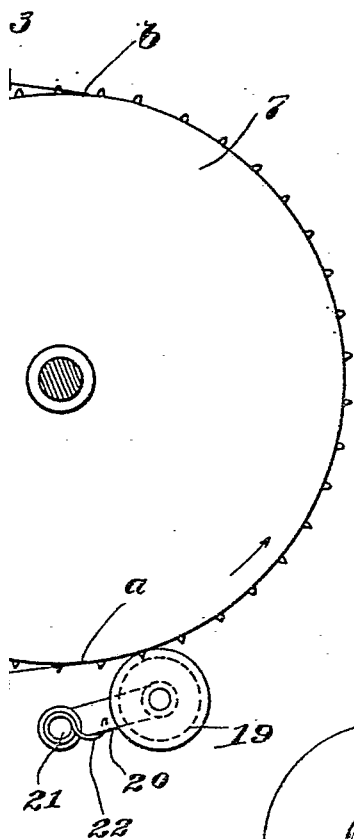
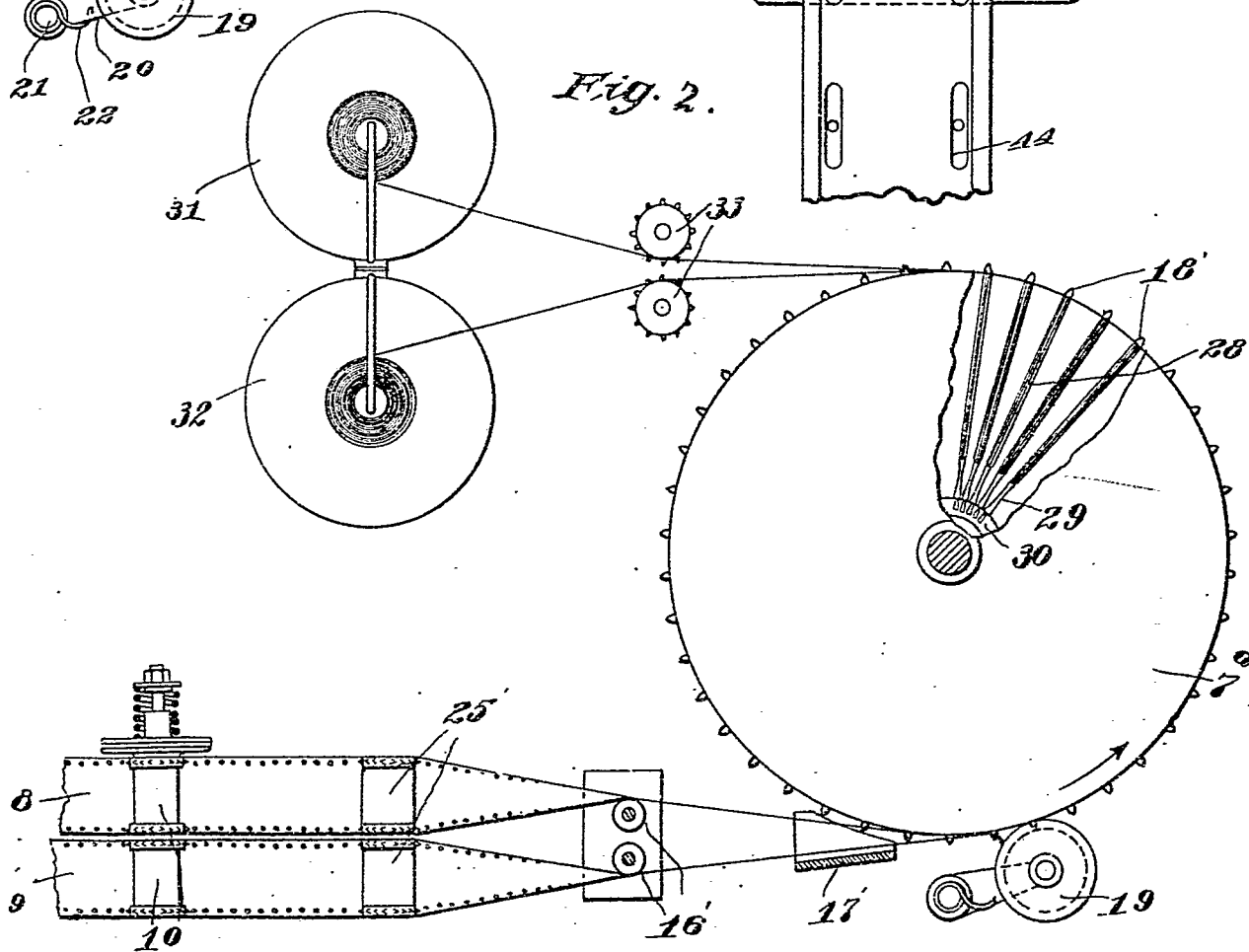

Fig. 2.



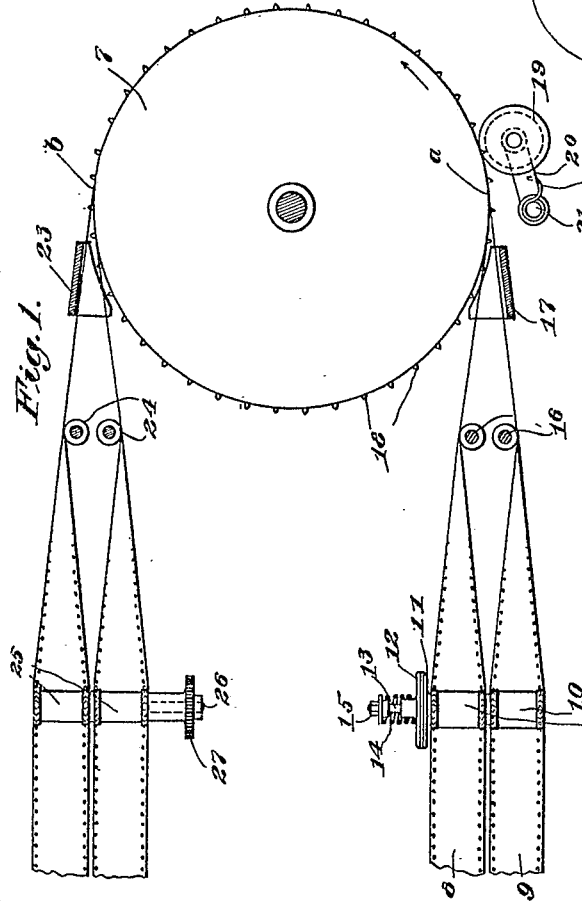

Fig. 1.

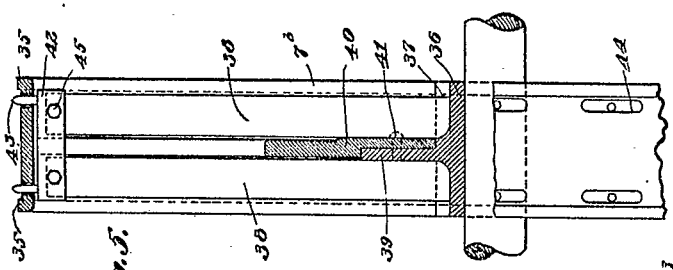

Fig. 2.

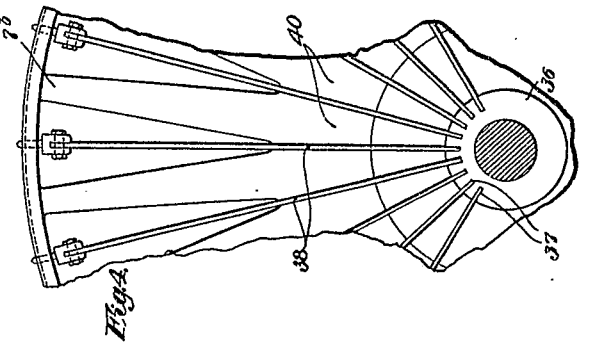

Fig. 3.

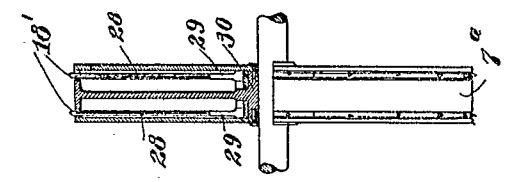

Fig. 4.

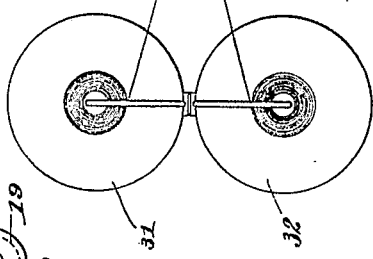

Fig. 5.

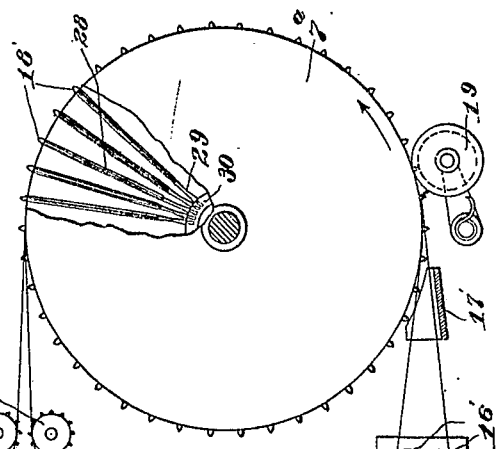

Fig. 6.

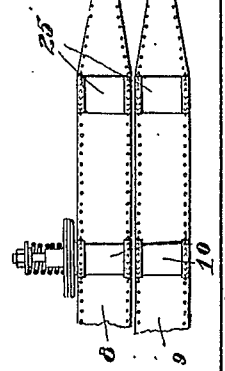
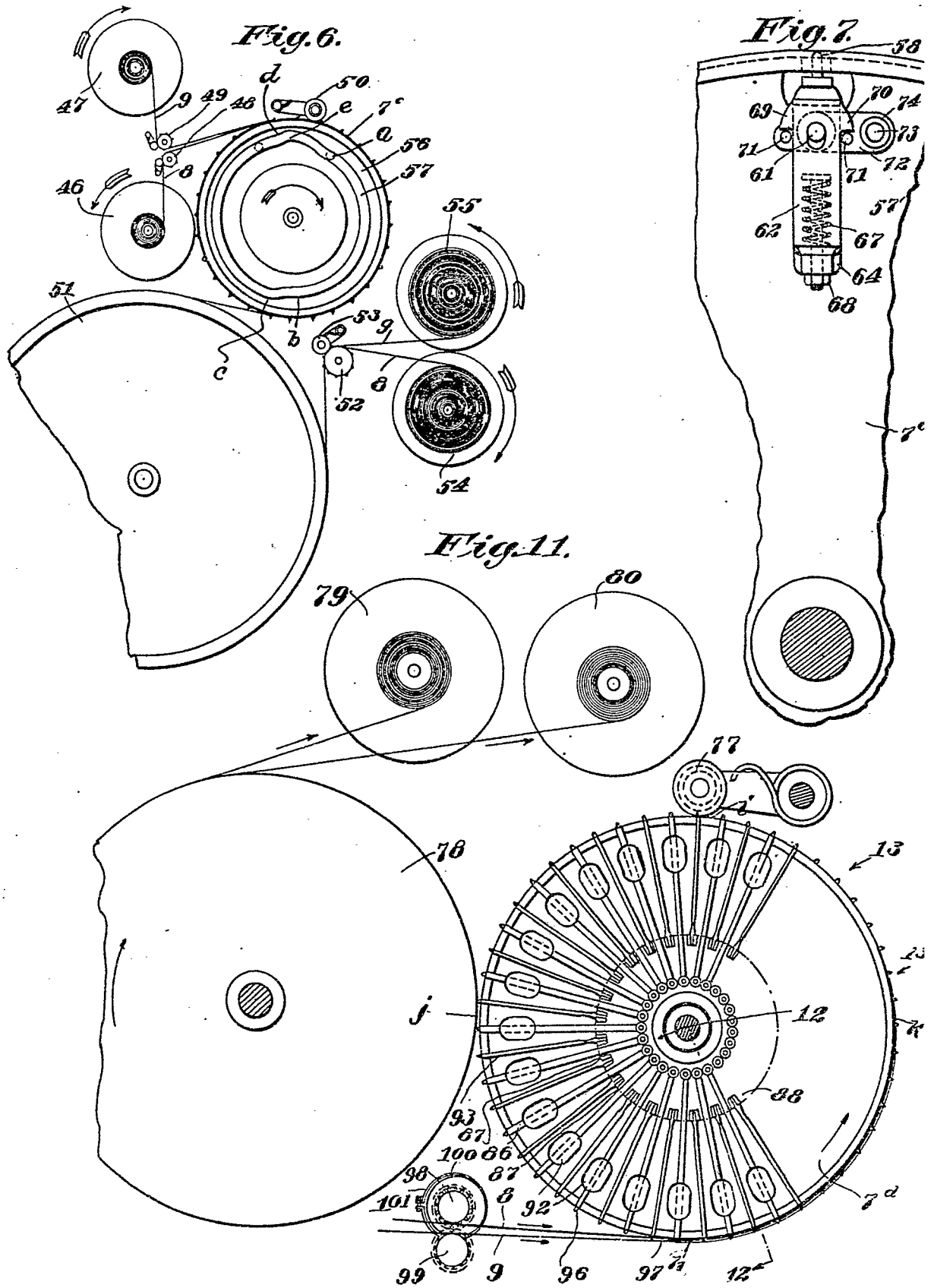
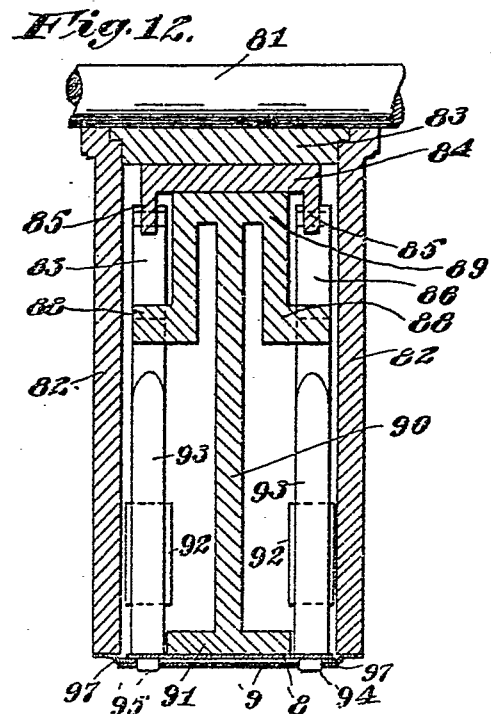
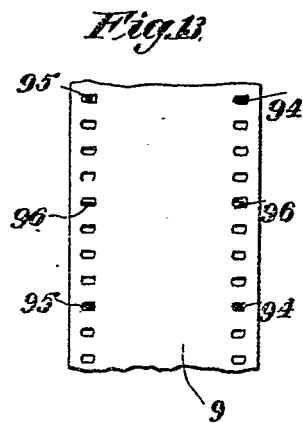
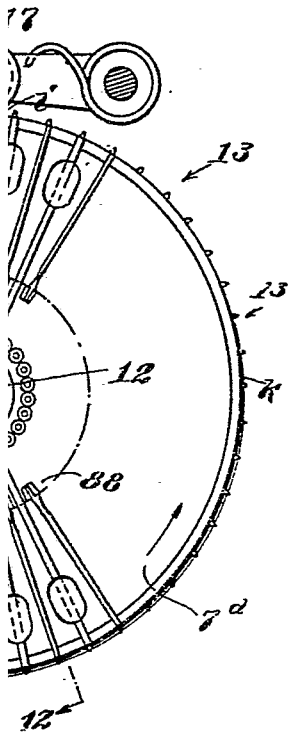
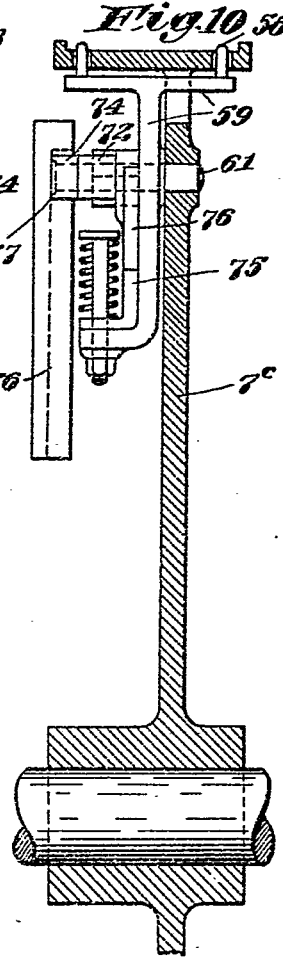
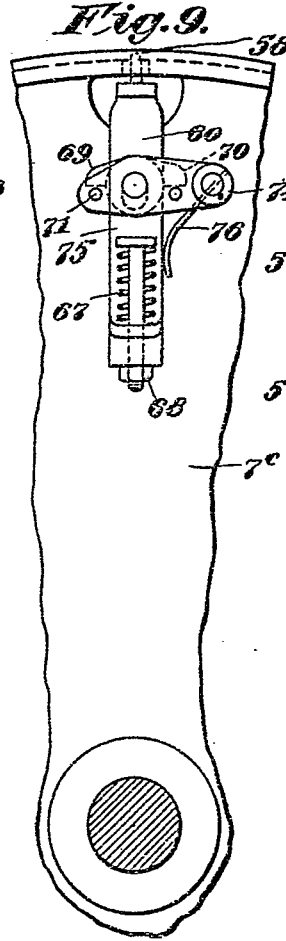
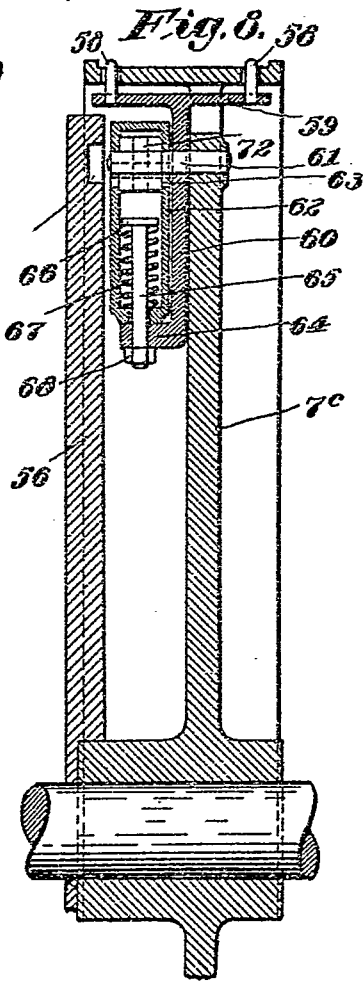
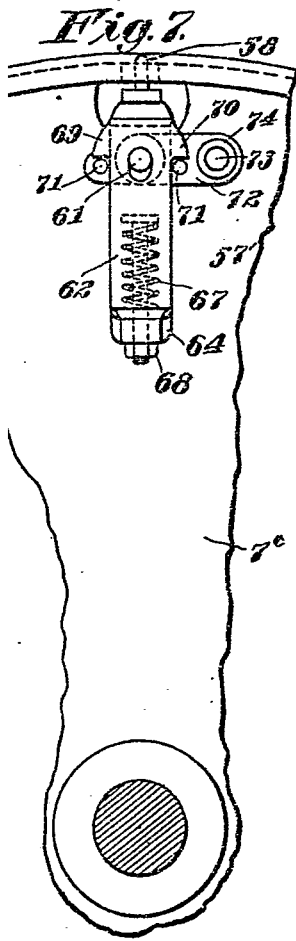

Fig. 7.

[This Drawing is a reproduction of the Original on a reduced scale.]

[This Drawing is a reproduction of the Original on a reduced scale.]





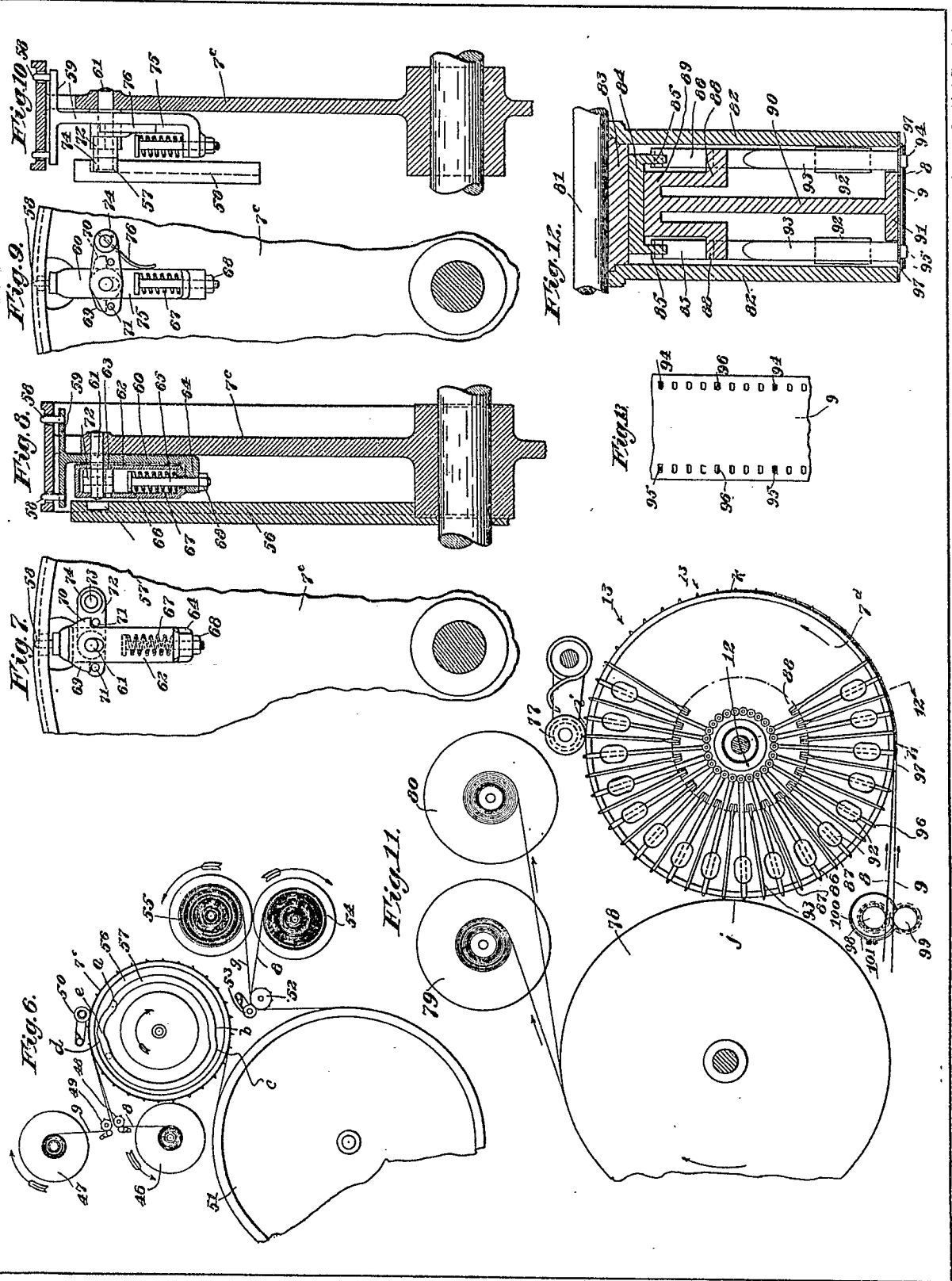

[This Drawing is a reproduction of the Original on a reduced scale]