

March 5, 1929.

J. F. KIENNINGER

1,704,328

SPEED CONTROL FOR IMBIBITION APPARATUS

Filed May 27, 1927

5 Sheets-Sheet 1

Fig. 1

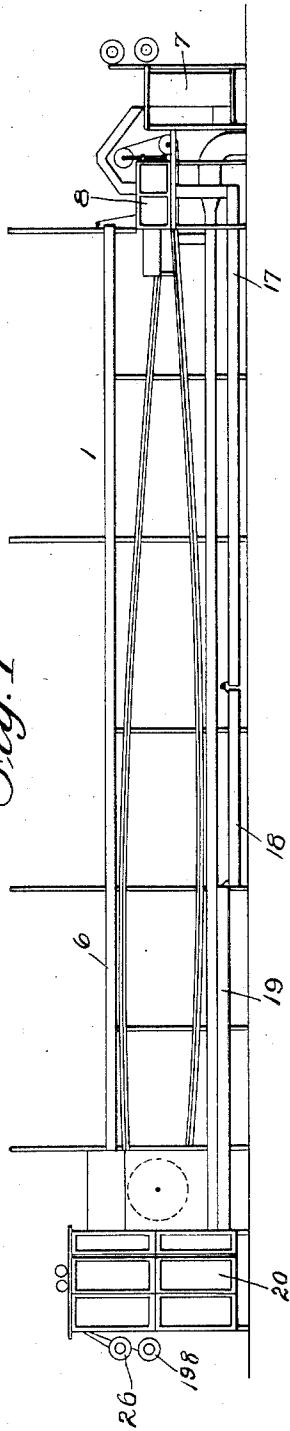
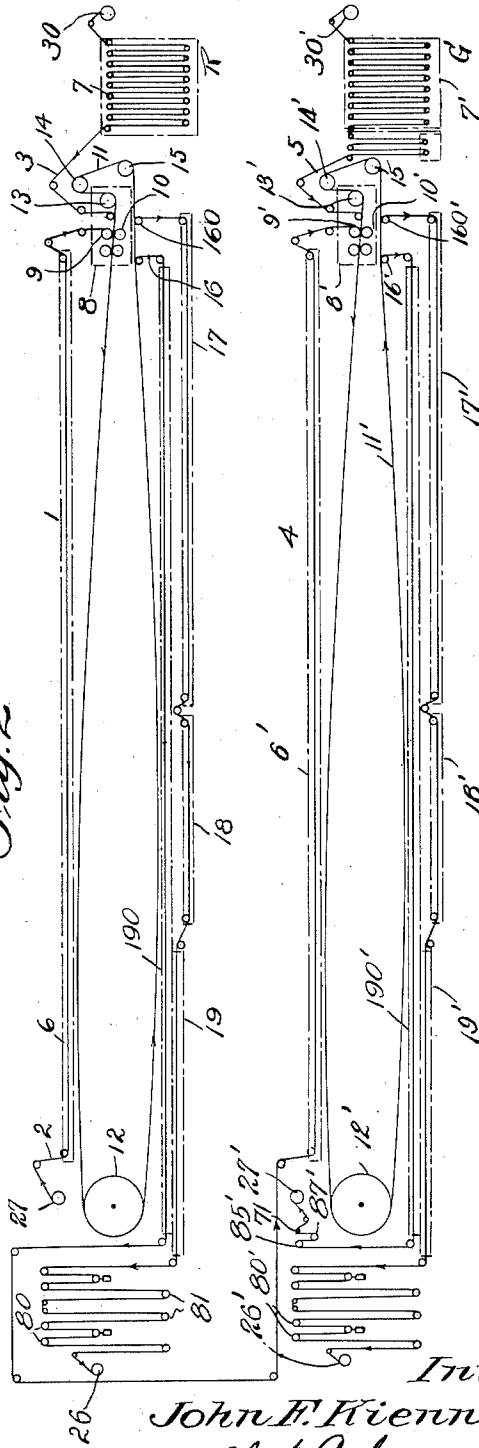

Fig. 2



Inventor
John F. Kienninger
by Robert Cushman & Woodberry
Att'ys

March 5, 1929.

J. F. KIENNINGER

1,704,328

SPEED CONTROL FOR IMBIBITION APPARATUS

Filed May 27, 1927

5 Sheets-Sheet 2

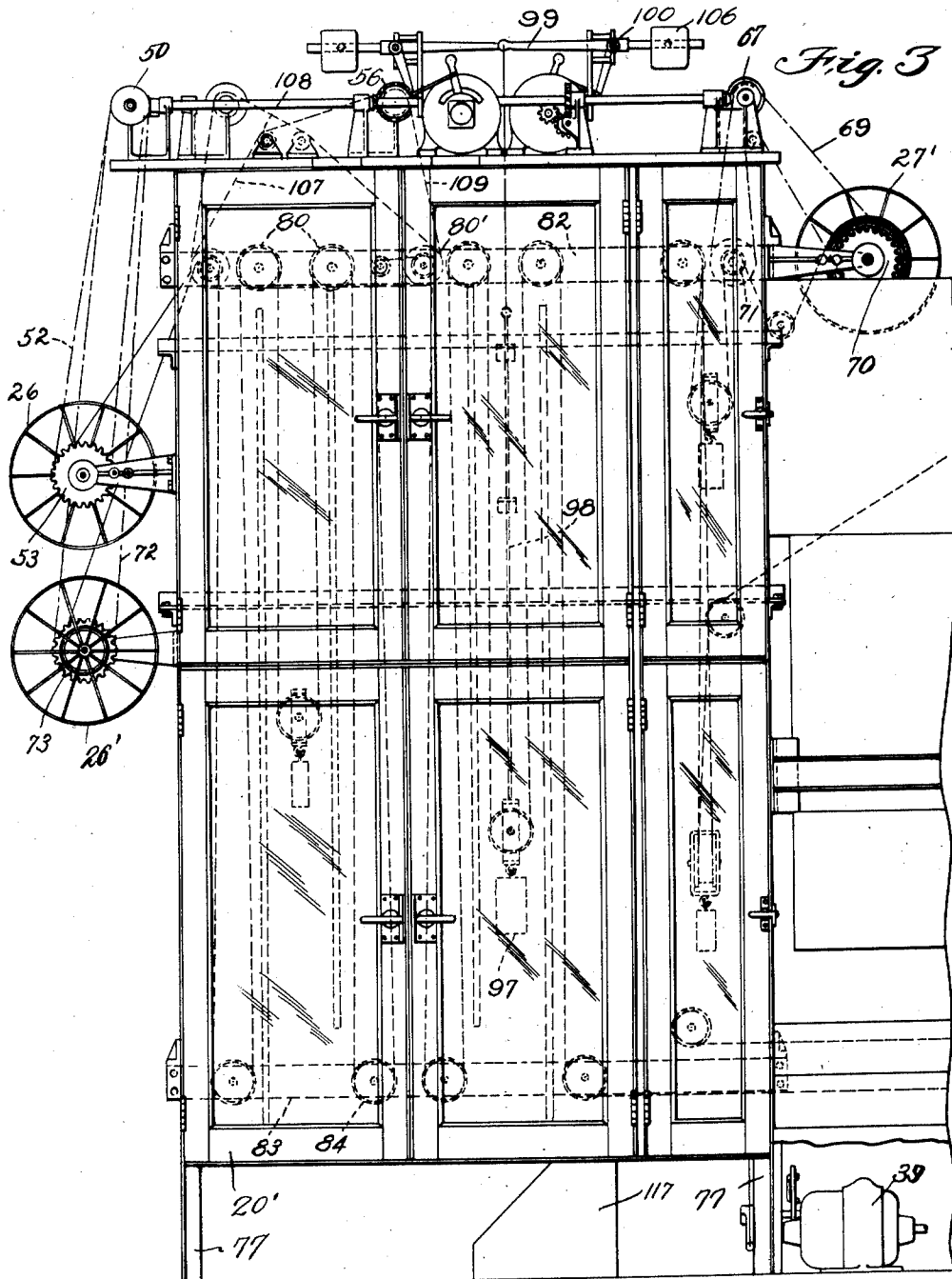

Inventor
John E. Kienninger
by Roberts, Cushman & Woodburn
Att'ys

March 5, 1929.

J. F. KIENNINGER

1,704,328

SPEED CONTROL FOR IMBIBITION APPARATUS

Filed May 27, 1927

5 Sheets-Sheet 3

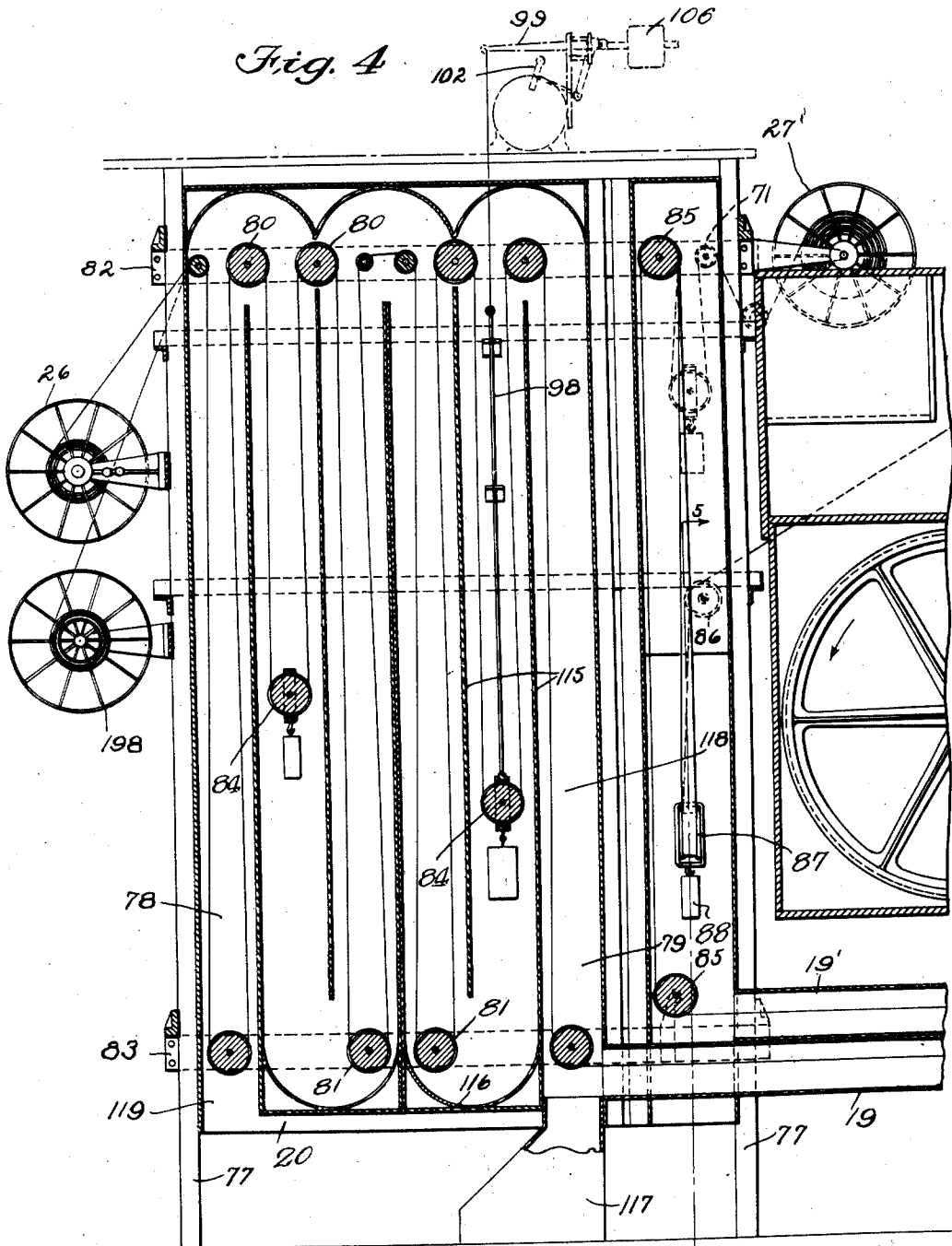

Inventor
John F. Kienninger
by Robert Cushman Woodberry
Attys

March 5, 1929.

J. F. KIENNINGER

1,704,328

SPEED CONTROL FOR IMBIBITION APPARATUS

Filed May 27, 1927

5 Sheets-Sheet 4

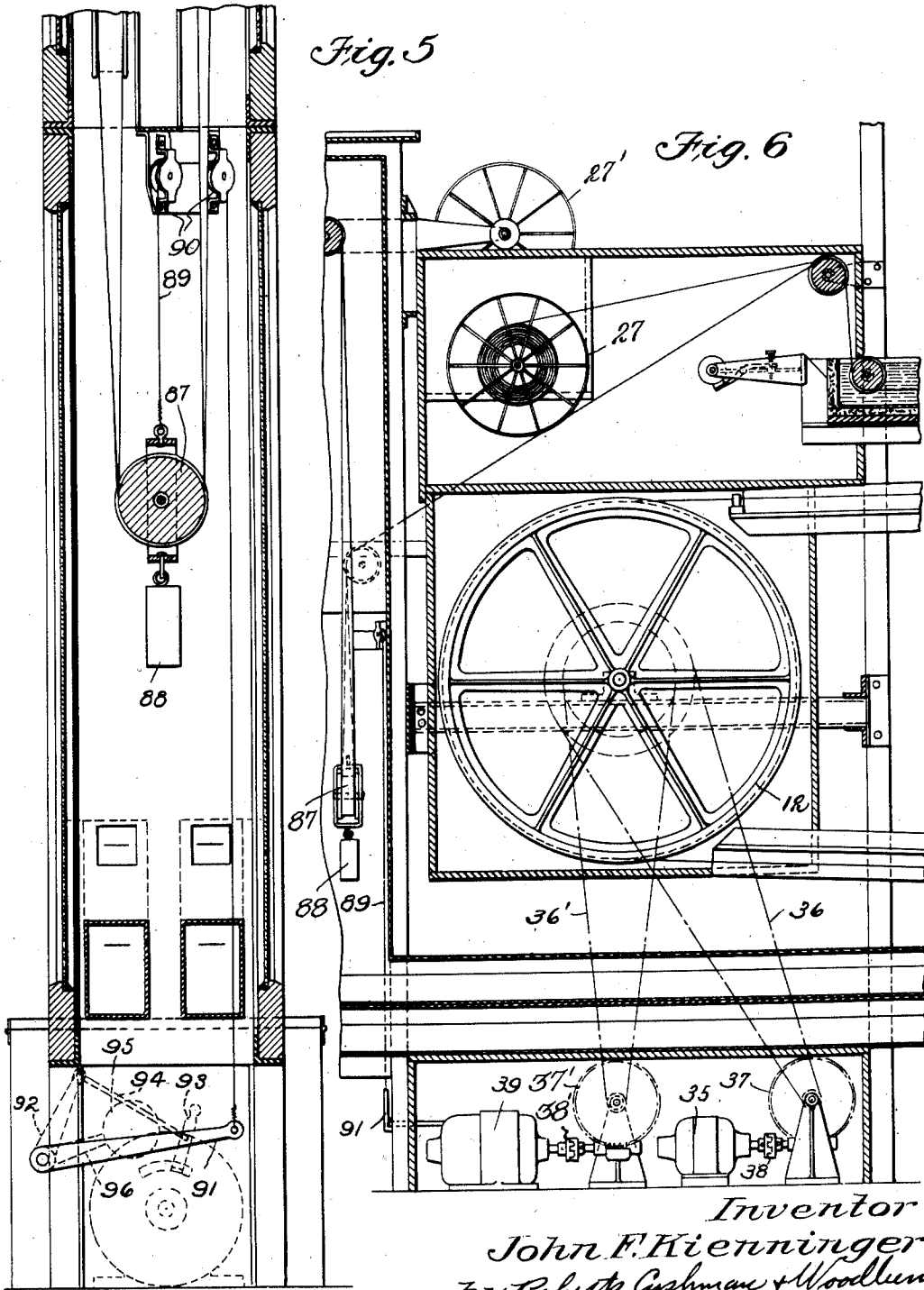

Inventor
John F. Kienninger
by Robert Cushman & Woodbury
Att'ys

March 5, 1929.

J. F. KIENNINGER

1,704,328

SPEED CONTROL FOR IMBIBITION APPARATUS

Filed May 27, 1927

5 Sheets-Sheet 5

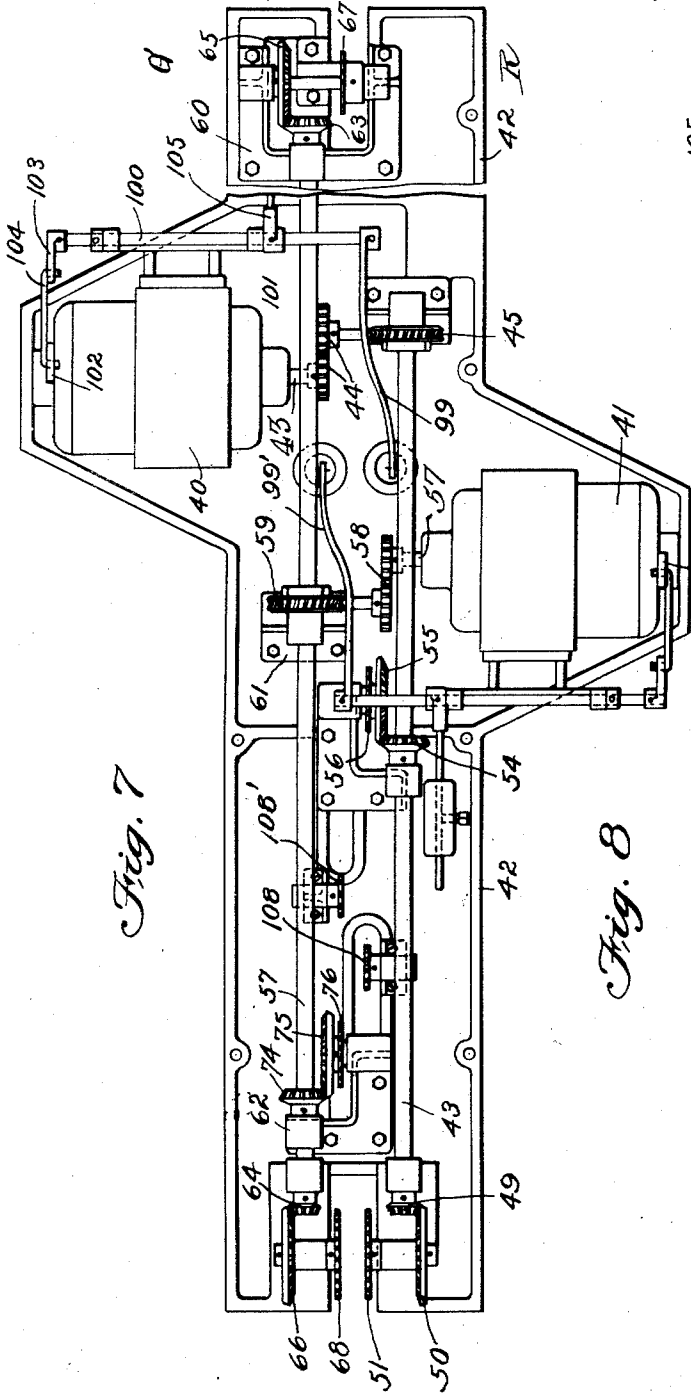

Fig. 7

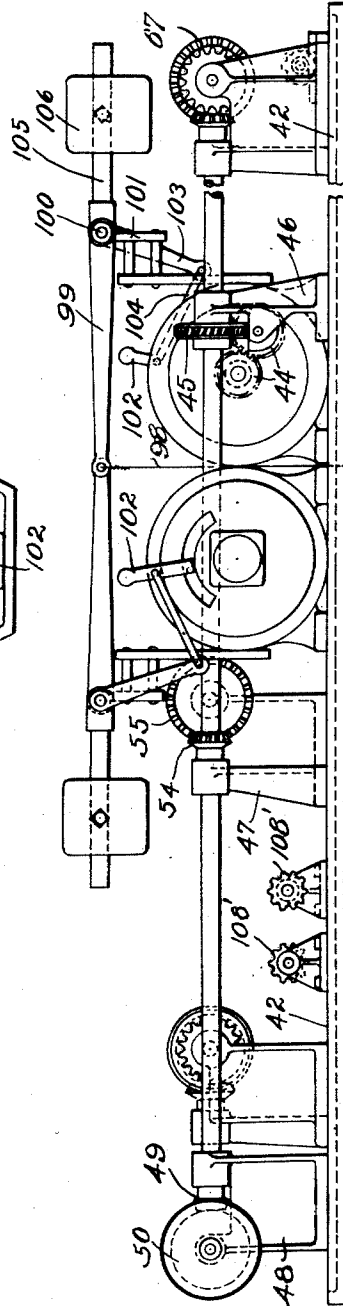

Fig. 8

Inventor
John F. Kienninger
by Robert Cushman & Woodbury
Att'ys

UNITED STATES PATENT OFFICE.

JOHN F. KIENNINGER, OF NORTH CAMBRIDGE, MASSACHUSETTS, ASSIGNOR, BY MESNE ASSIGNMENTS, TO TECHNICOLOR MOTION PICTURE CORPORATION, OF BOSTON, MASSACHUSETTS, A CORPORATION OF MAINE.

SPEED CONTROL FOR IMBIBITION APPARATUS.

Application filed May 27, 1927. Serial No. 194,840.

This invention relates to a method and apparatus for printing cinematographic films and the like, and more especially for effecting and controlling the regulated sequential movement of the matrix film and film to be printed, and the backing means therefore, without relative movement or distortion.

In the printing of cinematographic films by imbibition it has been proposed (co-pending application of Daniel F. Comstock, Serial No. 194,641, filed May 27, 1927) to provide a matrix film bearing the images to be reproduced, which is wet with a suitable dye and then brought into face contact with a similar blank film, such contact being preferably effected under water and maintained for a sufficient time to permit complete imbibition of the dye from the matrix film to the blank film to take place. The films are registered and thus retained in contact for the required interval by providing a backing strip (as with pins thereon for engagement with marginal sprocket holes in the films) which conveys the films in fixed contact relationship through a predetermined path, followed by separation of the films from the backing and from each other and other suitable or appropriate treatment. For example, the backing strip repeating the course of a closed circuit, the succeeding treatments may include the matrix film being washed, de-croceinated, (that is, cleared from any residual deposits of dye or color substance) dried, and reeled up, and the printed blank also being dried and reeled up or rewet and passed through one or more similar printing operations, if desired, as for the provision of remaining portions of the images in other or complementary colors with respect to those already applied.

In the conduct of such operations, it is essential that the films shall be restrained from relative movement after they have been brought into registry and/or contact with each other and also that the stresses and strains transmitted to the film longitudinally shall be equalized so far as may be possible, both during the period of imbibition contact and before and after such contact has been effected. In the handling of strips of the length frequently encountered with cinema films it is desirable that they shall be conveyed at a relatively uniform rate (for the purposes of convenient handling and of uniform printing treatment) and that the rate of one

shall synchronize with or substantially equal the rate of the other. On the other hand it is usually desirable that the rate of travel of the films, particularly during the imbibition period, shall be maintained relatively constant, so that the imbibition period with respect to successive portions of the films shall be substantially the same. Moreover, it is further desirable that such control shall be automatically effected and maintained.

Accordingly, it is an object of this invention to provide a method for accomplishing the conditions of operation above set forth and to provide means or apparatus whereby the same may be practically and easily carried out. Other objects of the invention will appear from the following disclosure and claims.

A typical and representative instance of the application of the invention will be described with respect to its adaptation for the imbibition printing of cinematographic films as carried out by means of apparatus shown in the accompanying drawings, of which:

Fig. 1 is a side elevation of two printing units R and G arranged in parallel and adapted for successive printing of a film in complementary colors;

Fig. 2 is a diagrammatic elevation of the units R and G of Fig. 1, one unit (R for printing in red) being shown above the other unit (G for printing in green) to illustrate the successive sequence of operations effected thereby;

Fig. 3 is an enlarged elevation of the drying and reeling portion of the apparatus shown at the left end of Fig. 1;

Fig. 4 is a longitudinal cross section of the apparatus shown in Fig. 3 taken centrally of the front unit (R) and also showing parts of the rear unit G;

Fig. 5 is a cross section in the plane of line 5—5 of Fig. 4, in the direction of the arrows;

Fig. 6 is an enlarged cross section of the apparatus extending to the right of that shown in Fig. 4;

Fig. 7 is an enlarged plan view of the driving mechanism shown at the top of Fig. 3; and

Fig. 8 is a side elevation of the apparatus shown in Fig. 7.

Referring to the drawings, and more especially Figs. 1 and 2, the apparatus shown consists generally of two units designated as R and G, which are substantially identical

and adapted to be operated in step with each other to print a cinematographic film, first in the red aspect, for example, and then in its complementary color or green aspect of the images to be reproduced. The units are arranged in parallel, so that, as shown in Fig. 1 the unit R (for printing in red) stands in front of and obscures the unit G while in the diagrammatic representation of Fig. 2 the unit R is raised above the rear unit G, to disclose the latter and to more clearly illustrate the operative relationship between the two units.

In the drawings, numeral 1 indicates generally an extended frame work, associated with suitable chambers, tanks, etc., and supporting and driving apparatus, for the unit R, while numeral 4 indicates a similar framework with respect to the unit G. Numeral 2 indicates the film strip to be printed which passes through both units, first in contact with red printing matrix film 3 and then with green matrix film 5. The unit R is provided with a pre-wetting tank of water 6, for the blank film 2 and a dye-wetting tank 7, for the matrix film, followed by a water tank 8, in which the films come together, having guide or compression rollers 9, 10, therein. A conveyor belt 11 preferably continuous and provided with suitable means (not shown in detail) for engaging the sprocket holes of the films, passes over driving pulley 12, idler pulleys 14, 15, and under pulley 13 in the tank 8. At the end of the belt traverse is provided an off-take pulley 16 for the printed film, and an off-take pulley 160 for the matrix film 3. Following the latter and to receive the matrix therefrom is provided a "decolorinating" tank so-called 17 for affecting removal of the residual dye, a washing tank 18 and a drying chamber 19, and also a drying chamber 20, which is followed by a gathering reel 26 (Figs. 1 and 4). Following the off-take pulley 160 is provided a drying conduit 190 for the printed film, leading to drying chamber 20 and thence (by means of apparatus subsequently to be described) to and through the apparatus constituting unit G. Unit G is substantially identical with unit R, commencing with water tank (6') and ending with the gathering reel (27'). However, while matrix film 3, is fed into the unit R from reel 30 a separate matrix film 5 is used in unit G which is complemental with respect to the color or images or other factors, of the representation to be printed.

The elements of unit G will be hereinafter referred to by the same numerals as like elements of the unit R, a prime being added thereto for purposes of differentiation, though in some instances the element of unit R may obscure or cover the corresponding element of unit G.

The driving impetus of the apparatus as a whole is primarily transmitted to the con-

veyor belt or backing 11, through driving pulley 12 in the unit G (and driving pulley 12' directly in the rear thereof in Fig. 6) but is shown only in part. Pulley 12 is driven by a constant speed motor 35 through a transmission belt 36, a worm gear 37 and connecting clutch 38. The other pulley 12' is driven by a variable speed motor 39 acting through similar transmission belt 36', gear 37' and connecting clutch 38'.

Turning now to the driving mechanism for reeling the blank film and matrix films, shown at the top of Fig. 3, but more particularly in Figs. 7 and 8, the parts are numbered in consecutive order without regard to the unit R or G with which it may be more closely associated. The motor 40 (mounted above unit G) and motor 41 (mounted above unit R) are contained on and within a framework 42. However, the motor 40, which is geared to shaft 43 through gears 44 and worm gear 45, serves to drive the matrix gathering apparatus of unit R. To this end, a terminal bevel gear 49 is provided, meshing with a like bevel gear 50 mounted upon the same axis with sprocket wheel 51. The latter carries a chain 52 which passes over sprocket 53 on reel 26, which serves to gather matrix film 3 from unit R (Figs. 2 and 3).

Motor 41 is likewise connected to a shaft 57 through gears 58 and worm gear 59. The shaft 57 is received in a bearing 60 near the right end and also is supported by a bearing 61 adjacent the worm gear 59 and a terminal bearing 62 near the opposite end. The right end of shaft 57 is provided with a bevel gear 63, meshing with bevel gear 65 on the axis of sprocket wheel 67 while the left end of the shaft carries a bevel gear 64 meshing with a bevel gear 66 on the axis of sprocket wheel 68. Sprocket chain 72 passes over the sprocket wheel 68 and over sprocket wheel 73 on reel 26' which serves to gather matrix film 5 from the unit G.

The sprocket wheel 67 (at the right of Fig. 7) carries sprocket chain 69, passing over sprocket wheel 70 on reel 27' and also over pulley 71, and thus provides for originally gathering the blank film 2 (after it has been printed by passing through both units R and G).

The shaft 57 is further provided with a bevel gear 74, meshing with a bevel gear 75 on the axis of sprocket wheel 76.

The chamber 20 (Figs. 3 and 4) is supported by uprights 77 and comprises two inlets, one for the film 2 which is being printed, as it comes from drying conduit 190, and one for the matrix film 3, as it comes from drying conduit 19, comprising several compartments, 79, vertically arranged and opening each into the next. Alternately, at the top and bottom of these compartments, are provided appropriate rollers or pulleys 80, 81, on cross bars 82, 83, respectively, and

intermediate floating pulleys or pulley blocks 84. The first mentioned opening from chamber 190 is provided with pulleys 85 to direct the film to be printed (2) between passes. A fixed pulley 86 conducts the printed film to the second unit of the apparatus, while a floating pulley or block 87 with weight 88 rides on the film between pulleys 85 and 86. A cord 89 attached to the block 87 (Fig. 5) leads over pulleys 90 to one end of control lever 91 which is attached through bell crank lever 92 and link 94 to an armature brush control lever 93 on the motor 39. The lever 91 also is associated with a counterweight 95 on arm 96, tending to oppose the positive actuation of the lever and to return it to a balanced position.

One of the floating pulleys 84 (Fig. 3) may be provided with weight 97 and a vertically extending rod 98 reaching upwardly to horizontal lever 99 which is attached to axis 100 carried by a support 101 and attached at its opposite end to control lever 102 on motor 40, through the lever 103 and link 104. The axis 100 also is attached to a horizontal arm 105 with adjustable counterweight, 106, held in position by a screw or nut.

Passing over sprocket wheels attached to the axes of the upper series of rollers 80 is a sprocket chain 107 engaging the driving sprocket wheel 56 and idler sprocket wheels 108. A similar length of the sprocket chain 109 engages sprocket wheel 76 and idler 108' and sprocket wheels on the axes of the corresponding rollers or pulleys 80' in the unit G.

The compartment 79, (Fig. 4) and intervening compartments of chamber 20 are separated by vertical partitions 115 which stop short of the top and bottom of the chamber 20, leaving passageways from each to the next which may be rounded off by semicircular walls 116 to form a continuous path for the film and drying gases. The first compartment may be connected to an air conduit 117 while the last compartment is left open, as at 119, to provide an exit for the air current.

The driving pulley 12 is positively driven by operation of constant speed motor 35 as will be obvious from Fig. 6. This draws the pre-wet blank 2 and the printing matrix 3 into the apparatus from their respective reels 27 and 30, respectively, at a substantially constant rate.

As the film blank 2, already printed in red, leaves conduit 190 it passes under lower pulley 85 over upper pulley 85 under the free pulley 87 and thence over fixed pulley 86 to the pre-wetting water tank 6'. In this intermediate zone the film provides a certain amount of slack which may serve to accommodate any differences in operation of the two units R and G and also at the outset to permit accurate registry of the film 2 with the second matrix film 5. After the printing with the second matrix film has commenced, how-

ever, it is desirable and practically necessary that the two units be run substantially in step with each other to prevent accumulation of the film on the one hand or rupture of the film on the other. The floating pulley 87 rides upon a loop of this slack portion of film 2, between the two units. Its rise and fall is a measure respectively, of the gain or loss in speed of operation of the second unit G over the first. Accordingly, as pulley 87 rises cord 89 is released and control lever 93 is allowed to fall back under the weight of ball 95 and thus to slow down the motor 39. Conversely, if the pulley 87 falls, cord 89 is drawn up, raising lever 93 and thus speeding up the motor 39, and hence speeding up the rate of travel of belt 11 in unit G. If it remains stationary, the two units are functioning at an equal rate of speed with respect to the film blank.

As the motor 39 speeds up it operates through transmission belt 36' upon driving pulley 12' and thus speeds up the rate of travel of conveyor belt or backing 11', taking up any accumulated excess of film delivered to it by belt 11. Conversely, when the motor 39 is slowed up (by reduction of slack film between the two units) the rate of rotation of the pulley 12' is reduced and the amount of intermediate slack film restored, since the rate at which film 2 is delivered to it is under constant operation of motor 35.

After the film 2 has passed through unit G (under actuation of belt 11' driven by pulley 12', see Fig. 2) it passes from conduit 190' over pulleys 85' similar to pulleys 85, already described, thence under floating pulley 87' and thence over fixed pulley 71 to reel 27'.

The reel 27' is operated directly through sprocket chain 69, passing over sprocket wheels 70 and 67, by the motor 40. The latter also operates the rollers 80 through sprocket 108 and gathering reel 26 through sprockets 52 for taking up the matrix film 3 coming from unit R. The speed of this motor is controlled by the rate at which the matrix film accumulates or is taken up in the drying chamber 20, as indicated by the rise and fall of rod 98 which has already been described.

Likewise the motor 41, controlled by similar speed indicating and regulating device (not shown) and acting through lever 99' drives rollers 80' (not shown) through sprocket chain 109, and sprocket chain 72 passing over sprocket 73, also drives reel 26'.

In this manner, the matrix film 3 and blank film 2 are drawn into unit R of the apparatus at a uniform and equal rate, upon the conveyor belt 11, upon which they are retained in fixed contact relationship until the blank film is separated and passed through conduit 19' and thence over the regulating mechanism (controlling motor 39) which has been described and which prevents continued gain or loss in the amount of blank film between the

two units. It is then passed to the second unit G, the rate of which is governed by the control apparatus just referred to,—returning through conduit 190' (behind conduit 190 but not shown) and thence over rolls 85 and 71 to gathering reel 27' which is driven by motor 40, controlled in step with the gathering of the matrix film 3, to be described.

As a result of the slight fluctuations of the rate at which the film blank 2 may be carried through the apparatus, the matrix film 3 is passed to chamber 20 at a slightly varying rate.

This may be due to slight variations in length of the film as well as to mechanical irregularities of the apparatus. The matrix film 3 as it is removed from the carrier belt 11, over pulley 16 and thence through the course already described accumulates and transmits such variations in speed to the floating pulley 84 and raises or lowers the same accordingly. This vertical movement is transmitted by rod 98 to horizontal bar 99 (balanced by counter-weight 106) and, acting through lever 103, link 104 and control lever 102, slows down or speeds up motor 40, thus correcting such deviations from a speed corresponding to the speed at which the film comes from conveyor belt 11 and the speed at which it is taken up upon the reel 26, and tending to insure synchronism or equality of the rate of operation in the several parts of the apparatus.

Similar or identical control means are provided in the chamber 20' of the unit G, to control the speed of motor 41 and hence the rate at which matrix film 5 is taken up by the reel 26'.

As thus operated, the apparatus is automatically controlled to conduct the films through their several paths at a predetermined rate and at speeds so regulated as to compensate for variations in the characteristic of the films and irregularities in operation of the separate parts or units of the apparatus, so that it functions as a whole.

It will be readily understood that numerous modifications and adaptations of the method and apparatus may be made in the method of procedure and in the equipment employed and that substitutions and additional features may be appended thereto, within the invention here disclosed. Such modifications are however, to be considered as comprehended by the above description and included by the terms of the following claims.

I claim:

1. A method for the imbibition printing of cinematographic films, which comprises passing a blank film into imbibition contact with a matrix film, conducting the contacting films through a predetermined path, separating the films, thereafter contacting the thus printed film in registry with a second matrix film, conducting the thus contacting films through

a predetermined path, separating the films, gathering the separated matrix and printed films, and controlling the rate of movement of the films in step with the relative speed of the printed film intermediate the printing steps.

2. A method for the imbibition printing of cinematographic films, which comprises passing a blank film into imbibition contact with a matrix film, conducting the contacting films through a predetermined path, separating the printed and matrix films, thereafter contacting the printed film in registry with a second matrix film, conducting the thus contacting films through a second predetermined path, separating the films, and controlling the rate of movement of the films through the second path in step with the relative speed of the film to be treated intermediate the printing steps.

3. A method for the imbibition printing of cinematographic films, which comprises passing a blank film into imbibition contact with a matrix film, conducting the contacting films through a predetermined path, at a substantially constant rate of speed, separating the printed and matrix films, thereafter contacting the printed film in registry with a second matrix film, conducting the thus contacting films through a second predetermined path, separating the films, and controlling the rate of movement of the films through the second path in step with the relative speed of the film to be treated intermediate the printing steps.

4. A method for the imbibition printing of cinematographic films, which comprises passing a blank film into imbibition contact with a matrix film, conducting the contacting films through a predetermined path, separating the printed and matrix films, thereafter contacting the printed film in registry with a second matrix film, conducting the thus contacting films through a second predetermined path, separating the films, and controlling the rate of movement of the films through the second path in step with the relative speed of the film to be treated intermediate the printing steps and finally gathering the printed film at a rate, in step with the rate at which the second matrix film is separated from the printed blank.

5. A method for the imbibition printing of cinematographic films, which comprises passing a blank film into imbibition contact with a matrix film, conducting the contacting films through a predetermined path, separating the films and thereafter contacting the printed film in registry with a second matrix film, conducting the thus contacting films through a predetermined path, and controlling the rate of movement of the films in step with the relative speed of the film to be treated intermediate the printing steps, separating the films, after the second printing, and finally gathering the printed film and matrix films

at a rate, in step with the rate at which one of the matrix films is separated from the printed blank.

5 6. Apparatus for printing cinematographic films, comprising a continuous conveyor, means for superposing a matrix film and blank film to be printed upon the conveyor, in registered contact, means for removing and separating the films, means for gathering the matrix film, means for transferring the printed film to and through subsequent steps of treatment, and control means for regulating the rate of gathering said film in step with the means for gathering the matrix film.

15 7. Apparatus for printing cinematographic films comprising a plurality of continuous conveyor means,—severally including means for superposing a matrix film and a blank film to be printed therefrom, means for conveying the same through a predetermined path and means for thereafter separating the same,—means for conducting the intervening portion of printed blank film continuously from each conveyor to and into contact with the matrix film on the next conveyor, and means for controlling the operation of the apparatus in step with the speed of said intervening section of the film to be printed.

25 8. Apparatus for printing cinematographic films comprising a plurality of continuous

conveyor means, severally including means for superposing a matrix film and a blank film to be printed, means for conveying the same through a predetermined path and means for thereafter separating the same, means for conducting the printed blank film continuously from one of said conveyors into contact with the matrix film on the next conveyor, and means for controlling the operation of the second conveyor in step with the speed of the intervening section of said film to be printed. 40

9. Apparatus for the imbibition printing of cinematographic films, comprising a plurality of conveyor means, severally including means for superposing a matrix film and blank film in registered contact, means for conveying the same through a predetermined path, means for conducting the blank film from the first of said conveyor to the second conveyor, means for severally gathering the matrix films coming from said conveyors, and means for controlling the speed of the second conveyor and of said gathering means in step with the speed of one of the matrix films. 45 50 55

Signed by me at Boston, Massachusetts, this ninth day of May, 1927.

JOHN F. KIENNINGER.